

# State of Nebraska - INVITATION TO BID CONTRACT

Date	1/4/23	Page	1 of 2
Solicitation Number	6750 OF		
Opening Date and Time	01/25/23	2:00 pm	
Buyer	CHRISTIE KELLY (AS)		

**DESTINATION OF GOODS**  
 DEPARTMENT OF TRANSPORTATION  
 5001 S 14TH ST  
 PO BOX 94759  
 LINCOLN NE 68509-4759

Per Nebraska's Transparency in Government Procurement Act, DAS is required to collect statistical information regarding the number of contracts awarded to Nebraska contractors. This information is for statistical purposes only and will not be considered for contract award purposes.

**NEBRASKA CONTRACTOR AFFIDAVIT:** Bidder hereby attests that bidder is a Nebraska Contractor. "Nebraska Contractor" shall mean any bidder who has maintained a bona fide place of business and at least one employee within this state for at least the six (6) months immediately preceding the posting date of this ITB.

\_\_\_\_\_ I hereby certify that I am a Resident disabled veteran or business located in a designated enterprise zone in accordance with Neb. Rev. Stat. §73-107 and wish to have preference, if applicable, considered in the award of this contract.

Contract to supply and deliver Articulated All Wheel Drive (AWD) Loader with Minimum 3.8 Cubic Yard (CY) Bucket to the State of Nebraska as per the attached specifications for a one (1) year period from date of award. The contract may be renewed for four (4) additional one (1) year periods when mutually agreeable to the vendor and the State of Nebraska.

(1/3/23 sc)

INVITATION					
Line	Description	Quantity	Unit of Measure	Unit Price	Extended Price
1	ARTICULATED AWD LOADER W/ 3.8 CU YD BUCKET	5.0000	EA	<u>278,000</u>	<u>1,390,000</u>
2	QUICK HITCH WITH SPECIFIED BUCKET	5.0000	EA	<u>13,000</u>	<u>65,000</u>
3	QUICK ATTACH FORKLIFT ASSEMBLY AS PER SPEC SHEET	5.0000	EA	<u>13,000</u>	<u>65,000</u>
4	MULTI PURPOSE BUCKET AS PER SPEC SHEET	5.0000	EA	<u>27,500</u>	<u>137,500</u>

**BIDDER MUST COMPLETE THE FOLLOWING**

DISCOUNT PAYMENT TERMS: Net % 30 DAYS

By signing this Invitation to Bid form, the bidder guarantees compliance with the provisions stated in this Invitation to Bid, agrees to the terms and conditions unless otherwise agreed to and certifies that bidder maintains a drug free work place environment. Vendor will furnish the items requested within \_\_\_\_\_ days after receipt of order. Failure to enter Delivery Date may cause quotation to be REJECTED.

210-300

Sign Here   
 (Authorized Signature Mandatory - Form must be signed manually in ink or by DocuSign)

Enter Contact Information Below

VENDOR# 1644823  
 VENDOR: Titan Machinery Inc.  
 Address: 6310 N 56th ST  
Lincoln, NE 68504

Contact Andy Berhel  
 Telephone 612-741-3321  
 Email andy.berhel@titanmachinery.com

# State of Nebraska - INVITATION TO BID CONTRACT

Date	1/4/23	Page	2 of 2
Solicitation Number	6750 OF		
Opening Date and Time	01/25/23	2:00 pm	
Buyer	CHRISTIE KELLY (AS)		

**DESTINATION OF GOODS**  
 DEPARTMENT OF TRANSPORTATION  
 5001 S 14TH ST  
 PO BOX 94759  
 LINCOLN NE 68509-4759

## INVITATION

Line	Description	Quantity	Unit of Measure	Unit Price	Extended Price
5	GRAPPLE FORK ATTACHMENT AS PER SPEC SHEET	5.0000	EA	<u>12,000</u>	<u>60,000</u>
6	WHEEL LOADER SCALE SYSTEM AS PER SPEC SHEET	5.0000	EA	<u>8,000</u>	<u>40,000</u>
7	DEDUCT EXTENDED WARRANTY AS PER SPEC SHEET	5.0000	EA	<u>&lt; 3,500 &gt;</u>	<u>&lt; 17,500 &gt;</u>
8	DELUXE AIR RIDE SEAT OPTION	5.0000	EA	<u>2,000</u>	<u>10,000</u>

**ADDENDUM ONE  
QUESTIONS and ANSWERS  
6750 OF**

Date: 01/18/23

To: All Bidders

From: Christie Kelly, Procurement Contracts Officer  
AS Materiel State Purchasing Bureau (SPB)

RE: Addendum for Invitation to Bid (ITB) Number 6750 OF for Articulated All Wheel Drive (AWD) Loader with Minimum 3.8 Cubic Yard (CY) Bucket to be opened on January 25, 2023, at 2:00 p.m. Central Time

Following are the questions submitted and answers provided for the above-mentioned ITB. The questions and answers are to be considered as part of the ITB.

**It is the Bidder's responsibility to check the SPB website for all Addenda or Amendments.**

<u>Question #</u>	<u>ITB Section Reference</u>	<u>ITB Page #</u>	<u>Question</u>	<u>State Response</u>
1	Section VI, Subsection E	29	Will the State of Nebraska accept equivalent tires as the Michelin XTLA?	If you are bidding anything but "Yes" or "No" please provide a "No & Provide Alternative" response as a narrative response in the "NOTES/COMMENTS" section of Subsection E explaining any deviation from the Bidder's ability to meet the condition, and an explanation of how this would be determined to be an acceptable alternative to meeting the condition. Alternatives must be detailed in such a way that allows such deviations to be fully evaluated. The State shall determine at its sole discretion whether or not the Bidder's alternative is an acceptable alternative.
2	Section VI, Subsection Q	34	Is manufacturers standard orange color acceptable?	If you are bidding anything but "Yes" or "No" please provide a "No & Provide Alternative" response as a narrative response in the "NOTES/COMMENTS" section of Subsection E explaining any deviation from the Bidder's ability to meet the condition, and an explanation of how this would be determined to be an acceptable alternative to meeting the condition. Alternatives must be detailed in such a way that allows such deviations to be fully evaluated. The State shall determine at its sole discretion whether or not the Bidder's alternative is an acceptable alternative.

This Addendum will become part of the ITB and should be acknowledged with the ITB.

Service Managers				
Location	Address	Name	Phone #	email
Omaha, NE	14961 Shepard Street	Terry Smith	402-733-3700	<a href="mailto:terry.smith@titanmachinery.com">terry.smith@titanmachinery.com</a>
Lincoln, NE	6310 North 56th St	Eric Weilage	402-464-3711	<a href="mailto:eric.weilage@titanmachinery.com">eric.weilage@titanmachinery.com</a>
North Platte, NE	3211 Rodeo Road	Mike Saba	308-532-6571	<a href="mailto:mike.saba@titanmachinery.com">mike.saba@titanmachinery.com</a>
Grand Island, NE	3721 West Hwy 2	Gil White	308-384-0310	<a href="mailto:gil.white@titanmachinery.com">gil.white@titanmachinery.com</a>
Hastings, NE	1660 So Baltimore Ave	Charles Monter	402-463-0544	<a href="mailto:charles.monter@titanmachinery.com">charles.monter@titanmachinery.com</a>
Kearney, NE	714 3rd Ave	Bryce Parker	308-237-3138	<a href="mailto:bryce.parker@titanmachinery.com">bryce.parker@titanmachinery.com</a>
Scottsbluff, NE	2401 West 20th Street	Adam Kriha	308-635-3727	<a href="mailto:adam.kriha@titanmachinery.com">adam.kriha@titanmachinery.com</a>
Windsor, CO	7250 Greenridge Road	Edward Neefe	970-461-4960	<a href="mailto:edward.neefe@titanmachinery.com">edward.neefe@titanmachinery.com</a>
Rapid City, SD	1441 Deadwood Ave	Carson Chord	605-388-0266	<a href="mailto:carson.chord@titanmachinery.com">carson.chord@titanmachinery.com</a>
Sioux Falls, SD	4400 West 62nd Street North	Kris McWilliams	605-336-3434	<a href="mailto:kris.mcwilliams@titanmachinery.com">kris.mcwilliams@titanmachinery.com</a>
Sioux City, IA	5601 Harbor Drive	Chris Hagen	712-239-4941	<a href="mailto:chris.hagen@titanmachinery.com">chris.hagen@titanmachinery.com</a>

**All Locations have certified service technicians and are OEM approved Parts, service and sales locations**

Parts Managers				
Location	Address	Name	Phone #	email
Omaha, NE	14961 Shepard Street	Lowell Taylor	402-733-3700	<a href="mailto:lowell.taylor@titanmachinery.com">lowell.taylor@titanmachinery.com</a>
Lincoln, NE	6310 North 56th St	Cody Sterns	402-464-3711	<a href="mailto:cody.sterns@titanmachinery.com">cody.sterns@titanmachinery.com</a>
North Platte, NE	3211 Rodeo Road	Ryan Docter	308-532-6571	<a href="mailto:ryan.docter@titanmachinery.com">ryan.docter@titanmachinery.com</a>
Grand Island, NE	3721 West Hwy 2	Jerry Ljunggren	308-384-0310	<a href="mailto:jerry.ljunggren@titanmachinery.com">jerry.ljunggren@titanmachinery.com</a>
Hastings, NE	1660 So Baltimore Ave	Justin Brader	402-463-0544	<a href="mailto:justin.brader@titanmachinery.com">justin.brader@titanmachinery.com</a>
Kearney, NE	714 3rd Ave	Thomas Swarm	308-237-3138	<a href="mailto:thomas.swarm@titanmachinery.com">thomas.swarm@titanmachinery.com</a>
Scottsbluff, NE	2401 West 20th Street	Thomas Peister	308-635-3727	<a href="mailto:thomas.piester@titanmachinery.com">thomas.piester@titanmachinery.com</a>
Windsor, CO	7250 Greenridge Road	Mark Willemsen	970-461-4960	<a href="mailto:mark.willemsen@titanmachinery.com">mark.willemsen@titanmachinery.com</a>
Rapid City, SD	1441 Deadwood Ave	Bryant Stilwell	605-388-0266	<a href="mailto:bryant.stilwell@titanmachinery.com">bryant.stilwell@titanmachinery.com</a>
Sioux Falls, SD	4400 West 62nd Street North	Bruce Wobig	605-336-3434	<a href="mailto:bruce.wobig@titanmachinery.com">bruce.wobig@titanmachinery.com</a>
Sioux City, IA	5601 Harbor Drive	Chris Hagan	712-239-4941	<a href="mailto:chris.hagan@titanmachinery.com">chris.hagan@titanmachinery.com</a>

**ARTICULATED ALL WHEEL DRIVE (AWD) LOADER  
WITH MINIMUM 3.8 CUBIC YARD (CY) BUCKET  
STATE OF NEBRASKA/NDOT  
INVITATION TO BID  
6750 OF**

The State of Nebraska (State), Department of Administrative Services (DAS), Materiel Division, State Purchasing Bureau (SPB), is issuing this solicitation for a commodity contract, ITB Number 6750 OF for the purpose of selecting a qualified Bidder to provide **Articulated All Wheel Drive (AWD) Loader with Minimum 3.8 Cubic Yard (CY) Bucket**. A more detailed description can be found in Sections II through VII. The resulting contract may not be an exclusive contract as the State reserves the right to contract for the same or similar goods from other sources now or in the future.

**INFORMATION PERTINENT TO THIS SOLICITATION CAN BE FOUND ON THE INTERNET AT:**

<http://das.nebraska.gov/materiel/purchasing.html>

**PUBLIC POSTING NOTICE:**

**Pursuant to the Taxpayer Transparency Act (Neb. Rev. Stat. §§ 84-602.01 to 84-602.04) and in furtherance of public records statutes (Neb. Rev. Stat. § 84-712 et seq.), State contracts, must be posted to a public website. The resulting Contract, the ITB, and the successful Bidder's entire bid and response will be posted to a public website managed by DAS, which can be found at:**

<https://statecontracts.nebraska.gov>

**If the Bidder wishes to withhold proprietary or other commercial information from disclosure, the Bidder must do the following:**

- a. Identify the Proprietary Information;
- b. Mark the Proprietary Information; and
- c. Submit the Proprietary Information under separate cover marked clearly using an indelible method with the words "PROPRIETARY INFORMATION".
- d. The mere assertion that information is Proprietary or that a speculative Business advantage might be gained is not sufficient. (See Attorney General Opinion No. 92068, April 27, 1992). **THE BIDDER MAY NOT ASSERT THAT THE ENTIRE BID IS PROPRIETARY. COST WILL NOT BE CONSIDERED PROPRIETARY AND IS A PUBLIC RECORD SUBJECT TO DISCLOSURE.**

The State may require a Bidder to submit more information, including, but not limited to, a detailed explanation as to how and why the designated information is Proprietary.

**The State will determine, in its sole discretion, if the disclosure of the designated Proprietary Information would:**

- a. Give advantage to Business competitors; and,
- b. Serve no public purpose.

Absent a determination by the State that the information may be withheld pursuant to Neb. Rev. Stat. § 84-712.05, the State will consider all information a public record subject to disclosure.

In the event that disclosure of Proprietary Information is ordered or requested, it will be the Bidder's responsibility to assert and defend the non-disclosure.

To facilitate public postings, with the exception of Proprietary Information, the State reserves a royalty-free, nonexclusive, and irrevocable right to copy, reproduce, publish, post to a website, or otherwise use any contract, bid, or response to this ITB for any purpose, and to authorize others to use the documents. Any individual or entity Awarded a contract, or who submits a bid in response to this ITB, specifically waives any Copyright or other protection the contract, bid, or response to the ITB may have; and acknowledges that they have the ability and authority to enter into such waiver. This reservation and waiver are a prerequisite for submitting a bid or response to this ITB, and Award of a contract. Failure to agree to the reservation and waiver will result in the bid being found non-responsive and rejected.

Any entity Awarded a contract or submitting a bid or response to the ITB agrees not to sue, file a claim, or make a demand of any kind, and will indemnify and hold harmless the State and its employees, volunteers, Agents, and its elected and appointed officials from and against any and all claims, liens, demands, damages, liability, actions, causes of action, losses, judgments, costs, and expenses of every nature, including investigation costs and expenses, settlement costs, and attorney fees and expenses, sustained or asserted against the State, arising out of, resulting from, or attributable to the posting of the contract or the bids and responses to the ITB, Awards, and other documents.

**INVITATION TO BID  
6750 OF**

**TABLE OF CONTENTS**

<b>TABLE OF CONTENTS</b> .....	<b>2</b>
<b>GLOSSARY OF TERMS</b> .....	<b>4</b>
<b>ACRONYM LIST</b> .....	<b>8</b>
<b>I. PROCUREMENT PROCEDURE</b> .....	<b>9</b>
A. GENERAL INFORMATION.....	9
B. PROCURING OFFICE AND COMMUNICATION WITH STATE STAFF AND EVALUATORS.....	9
C. SCHEDULE OF EVENTS.....	9
D. WRITTEN QUESTIONS AND ANSWERS.....	9
E. SECRETARY OF STATE/TAX COMMISSIONER REGISTRATION REQUIREMENTS (Statutory).....	10
F. ETHICS IN PUBLIC CONTRACTING.....	10
G. DEVIATIONS FROM THE ITB.....	10
H. SUBMISSION OF BIDS.....	10
I. BID PREPARATION COSTS.....	11
J. FAILURE TO COMPLY WITH ITB.....	11
K. BID CORRECTIONS.....	11
L. LATE BIDS.....	11
M. BID OPENING.....	12
N. ITB REQUIREMENTS.....	12
O. EVALUATION OF BIDS.....	12
P. BEST AND FINAL OFFER.....	12
Q. REFERENCE AND CREDIT CHECKS.....	13
R. AWARD.....	13
S. DISCOUNTS.....	13
T. PRICES.....	13
U. SPECIFICATIONS.....	13
V. ALTERNATE/EQUIVALENT BIDS.....	14
W. "LUMP SUM" OR "ALL OR NONE" BIDS.....	14
X. EMAIL SUBMISSIONS.....	14
Y. BID TABULATIONS.....	14
Z. REJECTION OF BIDS.....	14
AA. RESIDENT BIDDER.....	14
<b>II. TERMS AND CONDITIONS</b> .....	<b>15</b>
A. GENERAL.....	15
B. NOTIFICATION.....	15
C. PCO REPRESENTATIVE.....	16
D. GOVERNING LAW (Statutory).....	16
E. AMENDMENT.....	16
F. SUBSTITUTIONS.....	16
G. VENDOR PERFORMANCE REPORT(S).....	16
H. NOTICE OF POTENTIAL BIDDER BREACH.....	17
I. BREACH.....	17
J. NON-WAIVER OF BREACH.....	17
K. SEVERABILITY.....	17
L. INDEMNIFICATION.....	18
M. ATTORNEY'S FEES.....	18
N. ASSIGNMENT, SALE, OR MERGER.....	18
O. CONTRACTING WITH OTHER POLITICAL SUB-DIVISIONS OF THE STATE OR ANOTHER STATE.....	19
P. FORCE MAJEURE.....	19
Q. CONFIDENTIALITY.....	19
R. EARLY TERMINATION.....	19
<b>III. BIDDER DUTIES</b> .....	<b>21</b>
A. INDEPENDENT BIDDER / OBLIGATIONS.....	21
B. EMPLOYEE WORK ELIGIBILITY STATUS.....	21
C. COMPLIANCE WITH CIVIL RIGHTS LAWS AND EQUAL OPPORTUNITY EMPLOYMENT / NONDISCRIMINATION (Statutory).....	22
D. COOPERATION WITH OTHER BIDDERS.....	22

**INVITATION TO BID  
6750 OF**

E.	COST CLARIFICATION.....	22
F.	PERMITS, REGULATIONS, LAWS .....	22
G.	NOTICE OF POTENTIAL BIDDER BREACH .....	22
H.	ANTITRUST.....	23
I.	CONFLICT OF INTEREST .....	23
J.	ADVERTISING .....	23
K.	NEBRASKA TECHNOLOGY ACCESS STANDARDS (Statutory).....	23
L.	DISASTER RECOVERY/BACK UP PLAN.....	23
M.	DRUG POLICY.....	24
N.	WARRANTY .....	24
<b>IV.</b>	<b>PAYMENT .....</b>	<b>25</b>
A.	PROHIBITION AGAINST ADVANCE PAYMENT (Statutory).....	25
B.	TAXES (Statutory) .....	25
C.	INVOICES.....	25
D.	INSPECTION AND APPROVAL .....	25
E.	PAYMENT (Statutory).....	25
F.	LATE PAYMENT (Statutory).....	25
G.	SUBJECT TO FUNDING / FUNDING OUT CLAUSE FOR LOSS OF APPROPRIATIONS (Statutory).....	25
H.	RIGHT TO AUDIT (First Paragraph is Statutory) .....	25
<b>V.</b>	<b>SCOPE OF WORK .....</b>	<b>27</b>
A.	SCOPE .....	27
<b>VI.</b>	<b>TECHNICAL SPECIFICATIONS .....</b>	<b>28</b>
A.	BIDDER INSTRUCTIONS .....	28
B.	NON-COMPLIANCE STATEMENT .....	28
C.	ENGINE.....	28
D.	DRIVE 29 .....	
E.	TIRES AND WHEELS.....	29
F.	BRAKES .....	29
G.	STEERING .....	30
H.	LOADER.....	30
I.	CAB 30 .....	
J.	INSTRUMENTS .....	31
K.	HYDRAULIC SYSTEM .....	31
L.	COUNTERWEIGHTS .....	32
M.	GENERAL.....	32
N.	NOISE LEVEL .....	32
O.	RADIO FREQUENCY SHIELDING – CAUTION!!!.....	33
P.	MANUALS .....	33
Q.	MISCELLANEOUS .....	34
R.	TRAINING.....	34
S.	SPECIFICATION FORM(S).....	34
T.	ANNUAL USAGE, ESTIMATED .....	35
U.	USAGE REPORT .....	35
V.	DELIVERY ARO .....	35
W.	DELIVERY LOCATION.....	36
X.	ORDERS .....	36
Y.	QUALITY .....	36
Z.	WARRANTY .....	36
AA.	AUTHORIZED DEALER & WARRANTY .....	38
<b>VII.</b>	<b>OPTIONS.....</b>	<b>39</b>
A.	QUICK HITCH WITH SPECIFIED BUCKET .....	39
B.	QUICK ATTACH FORKLIFT ASSEMBLY.....	39
C.	MULTI-PURPOSE BUCKET.....	39
D.	GRAPPLE FORK ATTACHMENT .....	40
E.	WHEEL LOADER SCALE SYSTEM.....	40

**INVITATION TO BID  
6750 OF**

**GLOSSARY OF TERMS**

**Acceptance Test Procedure:** Benchmarks and other performance criteria, developed by the State or other sources of testing standards, for measuring the effectiveness of products or goods and the means used for testing such performance

**Addendum:** Something to be added or deleted to an existing document; a supplement

**Agency:** Using agencies shall mean and include all officers of the state, departments, bureaus, boards, commissions, councils, and institutions receiving legislative appropriations

**Agent/Representative:** A person authorized to act on behalf of another

**Amend:** To alter or change by adding, subtracting, or substituting

**Amendment:** A written correction or alteration to a document

**Appropriation:** Legislative authorization to expend public funds for a specific purpose. Money set apart for a specific use

**Automated Clearing House:** Electronic network for financial transactions in the United States

**Award:** All purchases, leases, or contracts which are based on competitive bids will be awarded according to the provisions in the solicitation

**Best and Final Offer:** In a competitive bid, the final offer submitted which contains Bidder's most favorable terms for price

**Bid:** An offer, proposal, or quote submitted by a contractor, vendor, or bidder in a response to a written solicitation

**Bidder:** A contractor or vendor who submits a bid in response to a written solicitation

**Breach:** Violation of a contractual obligation by failing to perform or repudiation of one's own promise.

**Business:** Any corporation, partnership, individual, sole proprietorship, joint-stock company, joint venture, or any other private legal entity

**Business Day:** Any weekday, except State-recognized holidays

**Calendar Day:** Every day shown on the calendar including Saturdays, Sundays, and State/Federal holidays

**Cancellation:** To call off or revoke a bid, purchase order or contract without expectation of conducting or performing at a later time

**Collusion:** An agreement or cooperation between two (2) or more persons or entities to accomplish a fraudulent, deceitful, or unlawful purpose

**Commodities:** Any equipment, material, supply, or goods; anything movable or tangible that is provided or sold

**Commodities Description:** Detailed descriptions of the items to be purchased; may include information necessary to obtain the desired quality, type, color, size, shape, or special characteristics necessary to perform the work intended to produce the desired results

**Competition:** The effort or action of two (2) or more commercial interests to obtain the same business from third parties

**Confidential Information:** Unless otherwise defined below, "Confidential Information" shall also mean proprietary trade secrets, academic and scientific research work which is in progress and unpublished, and other information which if released would give advantage to business competitors and serve no public purpose (see Neb. Rev. Stat. §84-712.05(3)). In accordance with Nebraska Attorney General Opinions 92068 and 97033, proof that information is proprietary requires identification of specific, named competitor(s) who would be advantaged by release of the information and the specific advantage the competitor(s) would receive

**Contract:** An agreement between two or more parties creating obligations that are enforceable or otherwise recognizable at law; the writing that sets forth such an agreement

**Contract Administration:** The management of the contract which includes and is not limited to contract signing, contract amendments and any necessary legal actions

**Contract Management:** The management of day-to-day activities at the Agency which includes and is not limited to ensuring deliverables are received, specifications are met, handling meetings, and making payments to the Bidder



## INVITATION TO BID 6750 OF

**Contract Period:** The duration of the contract

**Contractor:** An individual or entity lawfully conducting business in the State, who seeks or agrees to provide goods or services under the terms of a written contract.

**Cooperative Purchasing:** The combining of requirements of two (2) or more political entities to obtain advantages of volume purchases, reduction in administrative expenses or other public benefits

**Copyright:** A property right in an original work of authorship fixed in any tangible medium of expression, giving the holder the exclusive right to reproduce, adapt and distribute the work

**Customer Service:** The process of ensuring customer satisfaction by providing assistance and advice on those products or goods provided by a Bidder

**Default:** The omission or failure to perform a contractual duty

**Deviation:** Any proposed change(s) or alteration(s) to either the Terms and Conditions or deliverables within the scope of the written solicitation or contract

**Evaluation:** The process of examining a bid after opening to determine the Bidder's responsibility, responsiveness to requirements, and to ascertain other characteristics of the offer that relate to determination of the successful award

**Extension:** Continuance of a contract for a specified duration upon the agreement of the parties beyond the original Contract Period. Not to be confused with "Renewal Period"

**Free on-Board Destination:** The delivery charges are included in the quoted price and prepaid by the Bidder. Bidder is responsible for all claims associated with damages during delivery of product

**Foreign Corporation:** A foreign corporation that was organized and chartered under the laws of another state, government, or country.

**Grievance:** A complaint about a governmental action or decision related to the solicitation or resultant contract, brought by a Bidder who has timely submitted a bid response in connection with the award in question, to DAS Materiel Division or another designated Agency with the intention of achieving a remedial result

**Interested Party:** A person, acting in their personal capacity, or an entity entering into a contract or other agreement creating a legal interest therein

**Invalid Bid:** A bid that does not meet the requirements of the solicitation or cannot be evaluated against the other bids.

**Invitation to Bid:** A written solicitation utilized for obtaining competitive offers for Services or Goods

**Late Bid:** A bid received after the Opening Date and Time

**Mandatory:** Required, compulsory, or obligatory

**May:** Discretionary, permitted; used to express possibility

**Must:** See "Mandatory"

**National Institute for Governmental Purchasing:** Source used for assignment of universal commodity codes to goods and services

**Open Market Purchase:** Authorization may be given to an Agency to purchase items above direct purchase authority due to the unique nature, price, quantity, location of the using Agency, or time limitations by the DAS, SPB

**Opening Date and Time:** Specified date and time for the public opening of received, labeled, and sealed formal bids

**Outsourcing:** The contracting out of a business process which an organization may have previously performed internally or has a new need for, to an independent organization from which the process is purchased back

**Payroll & Financial Center:** Electronic procurement system of record

**Platform:** A specific hardware and Operating System combination that is different from other hardware and Operating System combinations to the extent that a different version of the Licensed Software product is required to execute properly in the environment established by such hardware and Operating System combination

**Point of Contact:** The person designated to receive communications and to communicate

## INVITATION TO BID 6750 OF

**Product:** Something that is distributed commercially for use or consumption and that is usually (1) tangible personal property, (2) the result of fabrication or processing, and (3) an item that has passed through a chain of commercial distribution before ultimate use or consumption

**Project:** The total scheme, program, or method worked out for the accomplishment of an objective, including all documentation, commodities, and goods to be provided under the contract

**Proposal:** An offer, bid, or quote submitted by a contractor, vendor, or bidder in a response to a written solicitation

**Proprietary Information:** Proprietary information is defined as trade secrets, academic and scientific research work which is in progress and unpublished, and other information which if released would give advantage to business competitors and service no public purpose (see Neb. Rev. Stat. § 84-712.05(3)). In accordance with Attorney General Opinions 92068 and 97033, proof that information is proprietary requires identification of specific named competitor(s) advantaged by release of the information and the demonstrated advantage the named competitor(s) would gain by the release of information

**Protest:** See "Grievance"

**Public Bid Opening:** The process of opening correctly submitted offers at the time and place specified in the written solicitation and in the presence of anyone who wished to attend

**Quote:** See "Bid"

**Recommended Hardware Configuration:** The data processing hardware (including all terminals, auxiliary storage, communication, and other peripheral devices) to the extent utilized by the State as recommended by the Bidder.

**Release Date:** The date of public release of the written solicitation to seek offers

**Renewal Period:** Optional contract periods subsequent to the original Contract Period for a specified duration with previously agreed to Terms and Conditions. Not to be confused with "Extension"

**Request for Information:** A general invitation to Bidder is requesting information for a potential future solicitation. The Request for Information is typically used as a research and information gathering tool for preparation of a solicitation

**Responsible Bidder:** A Bidder who has the capability in all respects to perform fully and lawfully all requirements with integrity and reliability to assure good faith performance

**Responsive Bidder:** A Bidder who has submitted a bid which conforms to all requirements of the solicitation document

**Shall:** See "Mandatory"

**Should:** Expected; suggested, but not necessarily mandatory

**Software License:** Legal instrument with or without printed material that governs the use or redistribution of licensed software

**Specifications:** The detailed statement, especially of the measurements, quality, materials, and functional characteristics, or other items to be provided under a contract

**Statutory:** These clauses are controlled by state law and are not subject to negotiation

**Subcontractor:** Individual or entity with whom the contractor enters a contract to perform a portion of the work awarded to the contractor

**Termination:** Occurs when the contract expires or either party, pursuant to a power created by agreement or law puts an end to the contract prior to the stated expiration date. All obligations which are still executory on both sides are discharged but any right based on prior breach or performance survives

**Third-Party:** Any person or entity, including but not limited to fiduciaries, shareholders, owners, officers, managers, employees, legally disinterested persons, and sub-contractors or agents, and their employees. It shall not include any entity or person who is an interested Party to the contract or agreement

**Trade Secret:** Information, including, but not limited to, a drawing, formula, pattern, compilation, program, device, method, technique, code, or process that (a) derives independent economic value, actual or potential, from not being known to, and not being ascertainable by proper means by, other persons who can obtain economic value from its disclosure or use; and (b) is the subject of efforts that are reasonable under the circumstances to maintain its secrecy (see Neb. Rev. Stat. § 87-502(4))

**Trademark:** A word, phrase, logo, or other graphic symbol used by a manufacturer or Bidder to distinguish its product from those of others, registered with the U.S. Patent and Trademark Office

**INVITATION TO BID  
6750 OF**

**Upgrade:** Any change that improves or alters the basic function of a product of service

**Vendor Performance Report:** A report completed by the using Agency and submitted to SPB documenting products or services delivered or performed which exceed or fail to meet the terms of the purchase order, contract, and/or solicitation specifications.

**Vendor:** Inclusive term for any Bidder or Contractor.

**Will:** See "Mandatory"

**INVITATION TO BID  
6750 OF**

**ACRONYM LIST**

**AC:** Alternating Current  
**ACH:** Automated Clearing House  
**ARO:** After Receipt of Order  
**AWD:** All Wheel Drive  
**BAFO:** Best and Final Offer  
**CY:** Cubic Yard  
**DAS:** Department of Administrative Services  
**DBA:** A Weighted Decibel  
**FOB:** Free on Board  
**ISO:** International Organization for Standardization  
**ITB:** Invitation to Bid  
**LED:** Light Emitting Diode  
**MHz:** Megahertz  
**MPH:** Miles Per Hour  
**NDOT:** Nebraska Department of Transportation  
**NIGP:** National Institute for Governmental Purchasing  
**OEM:** Original Equipment Manufacturer  
**OSHA:** Occupational Safety and Health Administration  
**PA:** Participating Addendum  
**PCO:** Procurement Contracts Officer  
**PFC:** Payroll and Financial Center  
**POC:** Point of Contact  
**PSI:** Pounds per Square Inch  
**RFI:** Request for Information  
**ROPS:** Rollover Protection Structure  
**RPM:** Revolutions per Minute  
**SAE:** Society of Automotive Engineers  
**SPB:** State Purchasing Bureau  
**UHF:** Ultra High Frequency  
**VHF:** Very High Frequency

**INVITATION TO BID  
6750 OF**

**I. PROCUREMENT PROCEDURE**

**A. GENERAL INFORMATION**

This ITB is designed to solicit bids from qualified Bidders who will be responsible for providing **Articulated AWD Loader with Minimum 3.8 CY Bucket** at a competitive and reasonable cost. Terms and Conditions, Project Description and Scope of Work, Bid instructions, and Cost Bid Requirements may be found in Sections II through VII.

Bids shall conform to all instructions, conditions, and requirements included in the bid. Prospective Bidders are expected to carefully examine all documents, schedules, and requirements in this bid, and respond to each requirement in the format prescribed. Bids may be found non-responsive if they do not conform to the bid.

**B. PROCURING OFFICE AND COMMUNICATION WITH STATE STAFF AND EVALUATORS**

Procurement responsibilities related to this ITB reside with SPB. The POC for this procurement is:

**ITB#:** 6750 OF  
**Name:** Christie Kelly, PCO  
**Agency:** SPB  
**Address:** 1526 K Street, Suite  
 Lincoln, NE 68508

**Telephone:** 402-471-6500

**E-Mail:** [as.materiel purchasing@nebraska.gov](mailto:as.materiel purchasing@nebraska.gov)

From the date the ITB is released until Intent to Award is posted, communication by a potential or actual bidder regarding this ITB is limited to the POC listed above. No employee of the State or evaluator is empowered to make binding statements regarding this ITB. The POC will issue, in writing, any answers or clarifications in the form of an Addendum regarding this ITB. Attempts to communicate with any Evaluator involved in this ITB in an attempt to influence this ITB is prohibited and may result in the Bidder being disqualified from this bid and future bid opportunities.

Notwithstanding the above paragraph, this ITB does not prohibit:

1. Communication regarding pre-existing contracts or obligations;
2. Communication required as outlined in the Schedule of Events or an event scheduled later by SPB; or,
3. Communication required for negotiation and execution of the final contract.

**C. SCHEDULE OF EVENTS**

The State expects to adhere to the procurement schedule shown below, but all dates are approximate and subject to change.

<b>ACTIVITY</b>		<b>DATE/TIME</b>
1.	Release ITB	January 4, 2023
2.	Last day to submit written questions. Upload written questions for 6750 OF electronically via ShareFile to: <a href="https://nebraska.sharefile.com/r-r75b7212f993a4ce9ad810b95845735a7">https://nebraska.sharefile.com/r-r75b7212f993a4ce9ad810b95845735a7</a>	January 11, 2023
3.	State responds to written questions through an Addendum to be posted to the Internet at: <a href="https://das.nebraska.gov/materiel/bidopps.htm#">https://das.nebraska.gov/materiel/bidopps.htm#</a>	January 18, 2023
4.	Electronic Bid Opening via Zoom Electronically submitted bids are being accepted due to the challenges of COVID-19. Upload electronic Bid submissions for 6750 OF via ShareFile to: <a href="https://nebraska.sharefile.com/r-r9fab140fb9304efc8d96be483a4f1c9f">https://nebraska.sharefile.com/r-r9fab140fb9304efc8d96be483a4f1c9f</a>  Zoom Meeting Information: <a href="https://us02web.zoom.us/j/7318536781?pwd=cHRFNDRzRzBwSitlVDZSQytEa2Zwdz09">https://us02web.zoom.us/j/7318536781?pwd=cHRFNDRzRzBwSitlVDZSQytEa2Zwdz09</a>  Meeting ID: 731 853 6781 Passcode: 4Gkv2f	January 25, 2023 2:00 PM Central Time

**D. WRITTEN QUESTIONS AND ANSWERS**

Questions regarding the meaning or interpretation of any solicitation provision must be submitted in writing to SPB and clearly marked "ITB Number 6750 OF; Articulated AWD Loader with Minimum 3.8 CY Bucket Questions". POC is not obligated to respond to questions that are received late per the Schedule of Events.

**INVITATION TO BID  
6750 OF**

Questions should be uploaded to ShareFile at <https://nebraska.sharefile.com/r-r75b7212f993a4ce9ad810b95845735a7> but may also be emailed.

The Bidder Should present, as questions, any assumptions upon which the Bidder's bid is or might be developed. Bids will be evaluated without consideration of any known or unknown assumptions. The Contract will not incorporate any known or unknown assumptions.

It is recommended that questions be submitted using the following format:

Solicitation Section Reference	Solicitation Page Number	Question

Written answers will be posted at <http://das.nebraska.gov/materiel/purchasing.html> per the Schedule of Events.

**E. SECRETARY OF STATE/TAX COMMISSIONER REGISTRATION REQUIREMENTS (Statutory)**

All Bidders must be authorized to transact business in the State and comply with all Nebraska Secretary of State Registration requirements. The Bidder who is the recipient of an Intent to Award will be required to certify that it has complied and produce a true and correct copy of its current (within ninety (90) calendar days of the intent to award) Certificate or Letter of Good Standing, or in the case of a sole proprietorship, provide written documentation of sole proprietorship and the United States Citizenship Attestation Form, available on the DAS website at: <http://das.nebraska.gov/materiel/purchasing.html>. This must be accomplished prior to execution of the contract.

**F. ETHICS IN PUBLIC CONTRACTING**

The State reserves the right to reject bids, withdraw an intent to award or award, or terminate a contract if a Bidder commits or has committed ethical violations, which include, but are not limited to:

1. Offering or giving, directly or indirectly, a bribe, fee, commission, compensation, gift, gratuity, or anything of value to any person or entity in an attempt to influence the bidding process;
2. Utilize the services of lobbyists, attorneys, political activists, or consultants to influence or subvert the bidding process;
3. Being considered for, presently being, or becoming debarred, suspended, ineligible, or excluded from contracting with any state or federal entity;
4. Submitting a bid on behalf of another party or entity;
5. Collude with any person or entity to influence the bidding process, submit sham bids, preclude bidding, fix pricing or costs, create an unfair advantage, subvert the bid, or prejudice the State.

The Bidder shall include this clause in any subcontract entered into for the exclusive purpose of performing this contract.

Bidder shall have an affirmative duty to report any violations of this clause by the Bidder throughout the bidding process, and throughout the term of this contract for the successful Bidder and their subcontractors.

**G. DEVIATIONS FROM THE ITB**

The requirements contained in the solicitation (Sections II through VII) become a part of the Terms and Conditions of the contract resulting from this solicitation. Any deviations from the solicitation in Sections II through VII must be clearly defined by the Bidder in its bid and, if accepted by the State, will become part of the contract. Any specifically defined deviations must not be in conflict with the basic nature of the solicitation, solicitation requirements, or applicable state or federal laws or statutes. "Deviation", for the purposes of this solicitation, means any proposed changes or alterations to either the contractual language or deliverables within the scope of this solicitation. The State discourages deviations and reserves the right to reject proposed deviations.

**H. SUBMISSION OF BIDS**

The State is accepting electronically submitted bids for this ITB.

**IT IS THE BIDDERS' RESPONSIBILITY TO ENSURE ALL BIDS SHALL BE SUBMITTED AS INSTRUCTED BELOW, BE MANUALLY SIGNED IN AN INDELIBLE MANNER OR BY DOCUSIGN AND RECEIVED BY THE DATE AND TIME INDICATED IN THE SCHEDULE OF EVENTS FOR EACH BID SUBMITTED TO BE EVALUATED.**

**\*\*\*DO NOT SUBMIT DOCUMENTS THAT HAVE BEEN SAVED WITH A PASSWORD\*\*\***

**SUBMITTING DOCUMENTS THAT HAVE BEEN SAVED WITH A PASWORD MAY MAKE IT IMPOSSIBLE FOR SPB TO DOWNLOAD YOUR BID/BID DOCUMENTS, THUS YOUR BID WILL BE NON-RESPONSIVE.**

**1. ELECTRONICALLY SUBMITTING ELECTRONIC BID(S)**

- a. Bidders should upload bid(s) via ShareFile to: <https://nebraska.sharefile.com/r-r9fab140fb9304efc8d96be483a4f1c9f>
- b. Not all browsers are compatible with ShareFile. Currently Chrome, Internet Explorer and Firefox are compatible, but Microsoft Edge is not.

**INVITATION TO BID  
6750 OF**

- c. **After the bidder clicks the bid submission link, the bidder will be prompted to enter contact information including an e-mail address so that the bidder will receive a confirmation email confirming the successful upload directly from ShareFile.**
  - d. The Bidder is solely responsible for any variance between the copies submitted.
  - e. If multiple bids are submitted, the State will retain only the most recently submitted response.
- 2. OTHER BID DOCUMENTS TO UPLOAD TO SHAREFILE**
- a. Any **Proprietary information** (if applicable) should be uploaded as separate and distinct files.
  - b. If it is the bidder's intent to submit multiple bids, the bidder must clearly identify each submission separately (see "Electronic ITB File Names" below).
  - c. It is the Bidder's responsibility to submit the Electronic Bid(s) and be received by the date and time of the Bid Opening indicated in the Schedule of Events.
  - d. **Hardware, software, internet, user, or electronic issues will not excuse a late bid.**
- 3. ELECTRONIC ITB FILE NAMES**
- a. The Bidder should clearly identify the uploaded Bid files.
  - b. **Do not submit bid file(s) more than 30 days prior to the Bid Opening. Once file(s) are uploaded they are only available for 30 days.**
  - c. **DO NOT ADD ANY LANGUAGE TO THE NAMING CONVENTIONS BELOW. Long titles can make the files difficult to work with AND CAN MAKE YOUR BID/BID DOCUMENTS UNABLE TO DOWNLOAD MAKING YOUR BID NON-RESPONSIVE.**
  - d. If the bidder submits the bid/bid documents as **one (1) complete packet (preferred method)**, please use the following naming convention:
    - **6750 OF LOADER MIN 3.8CY BUCKET <<NAME OF BIDDER>> Bid.**
  - e. If the bidder submits the bid/bid documents as separate files, please use the following naming convention(s):
    - **6750 OF LOADER MIN 3.8CY BUCKET <<NAME OF BIDDER>> Bid, File 1, File 2, File 3, etc....**
  - f. If multiple bids are submitted for the same ITB number, follow the same naming convention as letter "e", for example:
    - **6750 OF LOADER MIN 3.8CY BUCKET <<NAME OF BIDDER>> Bid 2, File 1, File 2, File 3, etc....**

Emphasis Should be concentrated on conformance to the ITB. Bids Should be clear and complete. If the bid is not presented clearly or is difficult to discern, in the sole opinion of the State, the State reserves the right to reject the bid

It is the responsibility of the Bidder to check the website often for all information relevant to this ITB to include Addenda and/or Amendments issued prior to the Opening Date and Time. The website address is: <https://das.nebraska.gov/materiel/bidopps.html>.

**I. BID PREPARATION COSTS**

The State shall not incur any liability for any costs incurred by Bidders in replying to this solicitation, including any activity related to bidding on this solicitation.

**J. FAILURE TO COMPLY WITH ITB**

Violation of the Terms and Conditions contained in this solicitation or any resultant contract, at any time before or after the award, shall be grounds for action by the State which may include, but is not limited to, the following:

1. Rejection of a Bidder's bid;
2. Withdrawal of the Intent to Award;
3. Withdrawal of the Award;
4. Negative Vendor Performance Report(s);
5. Termination of the resulting contract;
6. Legal action; or,
7. Suspension of the Bidder from further bidding with the State for the period of time relative to the seriousness of the violation, such period to be within the sole discretion of the State.

**K. BID CORRECTIONS**

A Bidder may correct a mistake in a bid prior to the time of opening by giving written notice to the State of intent to withdraw the bid for modification or to withdraw the bid completely. Changing a bid after opening may be permitted if the change is made to correct a minor error that does not affect price, quantity, quality, delivery, or contractual conditions. In case of a mathematical error in extension of price, unit price shall govern.

**L. LATE BIDS**

All bids must be received by SPB by the date and time of the Bid Opening per the Schedule of Events. It is the Bidder's responsibility to ensure timely submission and receipt and the State is not responsible for bids that are late or lost, regardless of cause or fault. No Late Bids will be evaluated. Late Bids may be returned to the bidder if requested by the Bidder within sixty (60) Calendar days after this late bid was submitted and will at the Bidder's expense.



## INVITATION TO BID 6750 OF

### M. BID OPENING

Anyone may attend the opening. It is considered a public opening. The PCO will read the names of the respondents. Depending upon the complexity of the bid for goods, the PCO may read the bids aloud or allow bids to be available for viewing by the public during the bid opening. Once the bid opening has concluded, the bids will not be available for viewing until the Intent to Award has been posted. An initial bid tabulation will be posted to the website as soon as feasible. Information identified as proprietary by the submitting Bidder, in accordance with the solicitation and state statute, will not be posted. If the state determines submitted information should not be withheld, in accordance with the Public Records Act, or if ordered to release any withheld information, said information may then be released. The submitting Bidder will be notified of the release and it shall be the obligation of the submitting Bidder to take further action if it believes the information should not be released.

### N. ITB REQUIREMENTS

The bids will first be examined to determine if all requirements listed below have been addressed and whether further evaluation is warranted. Bids not meeting the requirements may be rejected as non-responsive. The requirements are:

1. Original Commodity ITB form signed in an indelible manner or by DocuSign;
2. Clarity and responsiveness of the bid;
3. Completed Sections II through VII; and,
4. Completed ITB Form or State's Bid Sheet.

### O. EVALUATION OF BIDS

All bids that are responsive to the solicitation will be evaluated based on the following:

**Neb. Rev. Stat. § 81-161 allows the quality of performance of previous contracts to be considered when evaluating responses to competitively bid solicitations in determining the lowest responsible bidder.** Information obtained from any Vendor Performance Report (See Terms & Conditions, Section H) may be used in evaluating responses to solicitations for goods and services to determine the best value for the State.

**Neb. Rev. Stat. § 73-107 allows for a preference for a resident disabled veteran or business located in a designated enterprise zone.** When a state contract is to be awarded to the lowest responsible Bidder, a resident disabled veteran, or a business located in a designated enterprise zone under the Enterprise Zone Act shall be allowed a preference over any other resident or nonresident Bidder if all other factors are equal.

**Resident disabled veterans means any person (a) who resides in the State of Nebraska, who served in the United States Armed Forces, including any reserve component or the National Guard, who was discharged or otherwise separated with a characterization of honorable or general (under honorable conditions), and who possesses a disability rating letter issued by the United States Department of Veterans Affairs establishing a service-connected disability or a disability determination from the United States Department of Defense and (b)(i) who owns and controls a business or, in the case of a publicly owned business, more than fifty percent of the stock is owned by one or more persons described in subdivision (a) of this subsection and (ii) the management and daily business operations of the business are controlled by one or more persons described in subdivision(a) of this subsection. Any contract entered into without compliance with this section shall be null and void.**

Therefore, if a resident disabled veteran or business located in a designated enterprise zone submits a bid in accordance with Neb. Rev. Stat. § 73-107 and has so indicated on the ITB cover page under "Bidder must complete the following" requesting priority/preference to be considered in the award of this contract, the following will need to be submitted by the Bidder within ten (10) business days of request:

1. Documentation from the United States Armed Forces confirming service;
2. Documentation of discharge or otherwise separated characterization of honorable or general (under honorable conditions);
3. Disability rating letter issued by the United States Department of Veterans Affairs establishing a service-connected disability or a disability determination from the United States Department of Defense; and
4. Documentation which shows ownership and control of a business or, in the case of a publicly owned business, more than fifty percent of the stock is owned by one or more persons described in subdivision (a) of this subsection; and the management and daily business operations of the business are controlled by one or more persons described in subdivision (a) of this subsection.

Failure to submit the requested documentation within ten (10) business days of notice will disqualify the Bidder from consideration of the preference.

### P. BEST AND FINAL OFFER

If BAFO's are requested by the State and submitted by the Bidder, they will be evaluated (using the stated BAFO criteria) and ranked. The State reserves the right to conduct more than one (1) BAFO. The award will then be granted to the lowest responsible Bidder. However, a Bidder should provide its best offer in its original bid. Bidders should not expect that the State will request a BAFO.



**INVITATION TO BID  
6750 OF**

**Q. REFERENCE AND CREDIT CHECKS**

The State reserves the right to conduct and consider reference and credit checks. The State reserves the right to use third parties to conduct reference and credit checks. By submitting a bid in response to this solicitation, the Bidder grants to the State the right to contact or arrange a visit in person with any or all of the Bidder's clients. Reference and credit checks may be grounds to reject a bid, withdraw an intent to award, or rescind the award of a contract.

**R. AWARD**

The State reserves the right to evaluate bids and award contracts in a manner utilizing criteria selected at the State's discretion and in the State's best interest. After evaluation of the bids, or at any point in the solicitation process, the State of Nebraska may take one or more of the following actions:

1. Amend the solicitation;
2. Extend the time of or establish a new bid opening time;
3. Waive deviations or errors in the State's solicitation process and in Bidder bids that are not material, do not compromise the solicitation process or a Bidder's bid, and do not improve a Bidder's competitive position;
4. Accept or reject a portion of or all of a bid;
5. Accept or reject all bids;
6. Withdraw the solicitation;
7. Elect to rebid the solicitation;
8. Award single lines or multiple lines to one (1) or more Bidders; or,
9. Award one (1) or more all-inclusive contracts.

The State of Nebraska may consider, but is not limited to considering, one (1) or more of the following award criteria:

1. Price;
2. Location;
3. Quality;
4. Delivery time;
5. Bidder qualifications and capabilities; and,
6. State contract management requirements and/or costs.

The solicitation does not commit the State to award a contract. Once intent to award decision has been determined, it will be posted to the Internet at: <http://das.nebraska.gov/materiel/purchasing.html>

Any protests must be filed by a Bidder within ten (10) business days after the intent to award decision is posted to the Internet. Grievance and protest procedure is available on the Internet at: <http://das.nebraska.gov/materiel/purchasing.html>

**S. DISCOUNTS**

Prices quoted shall be inclusive of ALL trade discounts. Cash discount terms of less than thirty (30) days will not be considered as part of the bid. Cash discount periods will be computed from the date of receipt of a properly executed claim voucher or the date of completion of delivery of all items in a satisfactory condition, whichever is later.

**T. PRICES**

Prices quoted shall be net, including transportation and delivery charges fully prepaid by the Vendor, and FOB Destination as named in the ITB. **No additional charges will be allowed for packing, packages, or partial delivery costs.** When an arithmetic error has been made in the extended total the unit price will govern.

All prices, costs, and terms and conditions submitted in the bid shall remain fixed and valid commencing on the opening date of the bid and shall remain firm for the first one hundred twenty (120) days of the contract award.

Requests for an increase must be submitted in writing to SPB. SPB has a minimum of thirty (30) days to review and award any Price increase or decrease (after documentation is approved). Documentation will be required by the State to support the price increase. The State reserves the right to deny any requested price increase.

**No price increases are to be billed to the State prior to an Amendment to the Contract, which has been signed and completed by both the State and the awarded bidder, the Amendment is posted to the State Purchasing Bureau website and written notice has been given to both the State and the awarded bidder.**

**The State will be given full proportionate benefit of any decreases for the term of the contract.**

**U. SPECIFICATIONS**

Any manufacturer's names, trade names, brand names, information and/or catalog numbers listed in a specification are for reference and not intended to limit competition but will be used as the standard by which equivalent material offered will be judged. The Materiel Administrator or Designee will be the sole judge of equivalency. The Bidder may offer any brands which meets or exceeds the specification. When a specific product is required, the solicitation will so state. Any item bid is to be the latest current model under standard production at the time of order. No used or refurbished equipment will be accepted, unless otherwise stated.

**INVITATION TO BID  
6750 OF**

**V. ALTERNATE/EQUIVALENT BIDS**

Bidder may offer bids which are at variance from the express specifications of the solicitation. The State reserves the right to consider and accept such bids if, in the judgment of the Materiel Administrator or Designee, the bid will result in goods and/or services equivalent to or better than those which would be supplied in the original bid specifications. Bidder must indicate on the solicitation the manufacturer's name, number and shall submit with their bid, sketches, descriptive literature and/or complete specifications. Reference to literature submitted with a previous bid will not satisfy this provision. Bids which do not comply with these requirements are subject to rejection. In the absence of any stated deviation or exception, the bid will be accepted as in strict compliance with all terms, conditions and specifications, and the Bidder shall be held liable.

**W. "LUMP SUM" OR "ALL OR NONE" BIDS**

The State reserves the right to purchase "item-by-item", by groups or as a total when the State may benefit by so doing. Bidders may submit a bid on an "all or none" or "lump sum" basis but should also submit a bid on an "item-by-item" basis. The term "all or none" means a conditional bid which requires the purchase of all items on which bids are offered and Bidder declines to accept award on individual items; a "lump sum" bid is when the Bidder offers a lower price than the sum of the individual bids if all items are purchased but agrees to deliver individual items at the prices quoted.

**"LUMP SUM" OR "ALL OR NONE" BIDS SHOULD BE CONSPICUOUSLY MARKED ON THE FIRST PAGE OF THE ITB  
AND BID SHEET (IF APPLICABLE)**

**X. EMAIL SUBMISSIONS**

SPB will not accept bids by email, electronic, voice, or telephone bids **except** for one-time purchases under \$50,000.00.

**Y. BID TABULATIONS**

Bid tabulations are available on the website at: <https://das.nebraska.gov/materiel/bidopps.html>.

**Z. REJECTION OF BIDS**

The State reserves the right to reject any or all bids, wholly or in part, in the best interest of the State.

**AA. RESIDENT BIDDER**

Pursuant to Neb. Rev. Stat. §§ 73-101.01 through 73-101.02, a Resident Bidder shall be allowed a preference against a Non-resident Bidder from a state which gives or requires a preference to Bidders from that state. The preference shall be equal to the preference given or required by the state of the Nonresident Bidders. Where the lowest responsible bid from a resident Bidder is equal in all respects to one from a nonresident Bidder from a state which has no preference law, the resident Bidder shall be awarded the contract. The provision of this preference shall not apply to any contract for any project upon which federal funds would be withheld because of the provisions of this preference.

**INVITATION TO BID  
6750 OF**

**II. TERMS AND CONDITIONS**

**Bidders should complete Section II through VII as part of their bid.** Bidder is expected to read the Terms and Conditions and must initial either accept, reject, or reject and provide alternative language for each clause. The Bidder should also provide an explanation of why the Bidder rejected the clause or rejected the clause and provided alternate language using "Track Changes". Upon request an electronic copy of the bid with "Track Changes" must be submitted in an editable Word format. **By signing the solicitation, Bidder is agreeing to be legally bound by all the accepted Terms and Conditions, and any proposed alternative Terms and Conditions submitted with the bid.** The State reserves the right to negotiate rejected or proposed alternative language. If the State and Bidder fail to agree on the final Terms and Conditions, the State reserves the right to reject the bid. The State is soliciting bids in response to the solicitation. The State reserves the right to reject bids that attempt to substitute the Bidder's commercial contracts and/or documents for this solicitation.

The Bidder should submit with their bid any license, user agreement, service level agreement, or similar documents that the Bidder wants incorporated in the Contract. Upon notice of Intent to Award, the Bidder must submit a copy of these documents in an editable Word format. The State will not consider incorporation of any document not submitted with the Bidder's bid. These documents shall be subject to negotiation and will be incorporated as addendums if agreed to by the Parties.

If a conflict or ambiguity arises after the addendums have been negotiated and agreed to, the addendums shall be interpreted as follows:

1. If only one (1) Party's document has a particular clause, then that clause shall control;
2. If both Party's documents have a similar clause, but the clauses do not conflict, the clauses shall be read together; and,
3. If both Party's documents have a similar clause, but the clauses conflict, the State's clause shall control.

**A. GENERAL**

Accept (Initial)	Reject (Initial)	Reject & Provide Alternative Response (Initial)	NOTES/COMMENTS:
AB			

The contract resulting from this solicitation shall incorporate the following documents:

1. ITB and Addenda;
2. Amendments to the solicitation;
3. Questions and Answers;
4. Bidder's bid response;
5. The executed Contract and any Addenda, if applicable, and properly submitted documents; and,
6. Amendments to the Contract

Unless otherwise specifically stated in a future contract amendment, in case of any conflict between the incorporated documents, the documents shall govern in the following order of preference with number one (1) receiving preference over all other documents and with each lower numbered document having preference over any higher numbered document: 1) Amendment to the executed Contract with the most recent dated amendment having the highest priority, 2) executed Contract and any attached Addenda, 3) Amendments to bid and any Questions and Answers, 4) the original bid document and any Addenda, and 5) the Bidder's submitted Bid. Any ambiguity or conflict in the contract discovered after its execution, not otherwise addressed herein, shall be resolved in accordance with the rules of contract interpretation as established in the State.

**B. NOTIFICATION**

Accept (Initial)	Reject (Initial)	Reject & Provide Alternative Response (Initial)	NOTES/COMMENTS:
AB			

Communication regarding the executed contract shall be given in writing and deemed to have been delivered via email to the specified Contract Contact information provided on the submitted ITB form with the submitted bid(s). The Vendor should send written notice to the SPB. The State will send notices to the authorized contact provided on the ITB form. Either party may change its address for notification purposes by giving notice of the change and setting forth the new address and an effective date.

**INVITATION TO BID  
6750 OF**

**C. PCO REPRESENTATIVE**

The State reserves the right to appoint a PCO's Representative to manage [or assist the PCO in managing] the contract on behalf of the State. The PCO's Representative will be appointed in writing, and the appointment document will specify the extent of the PCO's Representative authority and responsibilities. If a PCO's Representative is appointed, the Bidder will be provided a copy of the appointment document and is expected to cooperate accordingly with the PCO's Representative. The PCO's Representative has no authority to bind the State to a contract, amendment, addendum, or other change or addition to the contract.

**D. GOVERNING LAW (Statutory)**

Notwithstanding any other provision of this contract, or any amendment or addendum(s) entered into contemporaneously or at a later time, the parties understand and agree that, (1) the State of Nebraska is a sovereign state and its authority to contract is therefore subject to limitation by the State's Constitution, statutes, common law, and regulation; (2) this contract will be interpreted and enforced under the laws of the State of Nebraska; (3) any action to enforce the provisions of this contract must be brought in the State of Nebraska per state law; (4) the person signing this contract on behalf of the State of Nebraska does not have the authority to waive the State's sovereign immunity, statutes, common law, or regulations; (5) the indemnity, limitation of liability, remedy, and other similar provisions of the final contract, if any, are entered into subject to the State's Constitution, statutes, common law, regulations, and sovereign immunity; and, (6) all terms and conditions of the final contract, including but not limited to the clauses concerning third-party use, licenses, warranties, limitations of liability, governing law and venue, usage verification, indemnity, liability, remedy or other similar provisions of the final contract are entered into specifically subject to the State's Constitution, statutes, common law, regulations, and sovereign immunity. The Parties must comply with all applicable local, state, and federal laws, ordinances, rules, orders, and regulations.

**E. AMENDMENT**

This Contract may be amended in writing, within scope, upon the agreement of both parties.

**F. SUBSTITUTIONS**

Accept (Initial)	Reject (Initial)	Reject & Provide Alternative Response (Initial)	NOTES/COMMENTS:
AB			

In the event any product is discontinued or replaced upon mutual consent during the contract period or prior to delivery, the State reserves the right to amend the contract or purchase order to include the alternate product at the same price.

**If the Vendor requests to substitute any contracted item and the substitute meets or exceeds the original specifications, the State may accept or reject the substitution.**

**If the Vendor requests to substitute any contracted item, which meets or exceeds the original specifications, and the cost of the substitute is higher, the State may accept or reject the substitution and price change.**

If the State and the Vendor do not agree to the requested substitution and price change, the Contract may be terminated immediately by the State. In the event any product is discontinued or replaced upon mutual consent and prior to delivery during the Contract Period the State reserves the right to amend the contract or purchase order to include the alternate product.

**\*\*\*Bidder will not substitute any item that has been awarded without prior written approval of SPB\*\*\***

**G. VENDOR PERFORMANCE REPORT(S)**

Accept (Initial)	Reject (Initial)	Reject & Provide Alternative Response (Initial)	NOTES/COMMENTS:
AB			

The State may document any instance(s) of products or services delivered or performed which exceed or fail to meet the terms of the purchase order, contract, and/or solicitation specifications. The SPB may contact the Vendor regarding any such report. Vendor performance report(s) will become a part of the permanent record of the Vendor.

**INVITATION TO BID  
6750 OF**

**H. NOTICE OF POTENTIAL BIDDER BREACH**

Accept (Initial)	Reject (Initial)	Reject & Provide Alternative Response (Initial)	NOTES/COMMENTS:
AB			

If Bidder breaches the contract or anticipates breaching the contract, the Bidder shall immediately give written notice to the State. The notice shall explain the breach or potential breach, a proposed cure, and may include a request for a waiver of the breach if so desired. The State may, in its discretion, temporarily or permanently waive the breach. By granting a waiver, the State does not forfeit any rights or remedies to which the State is entitled by law or equity, or pursuant to the provisions of the contract. Failure to give immediate notice, however, may be grounds for denial of any request for a waiver of a breach.

**I. BREACH**

Accept (Initial)	Reject (Initial)	Reject & Provide Alternative Response (Initial)	NOTES/COMMENTS:
AB			

Either Party may terminate the contract, in whole or in part, if the other Party breaches its duty to perform its obligations under the contract in a timely and proper manner. Termination requires written notice of default and a thirty (30) calendar day (or longer at the non-breaching Party's discretion considering the gravity and nature of the default) cure period. Said notice shall be delivered by Certified Mail, Return Receipt Requested, or in person with proof of delivery. Allowing time to cure a failure or breach of contract does not waive the right to immediately terminate the contract for the same or different contract breach which may occur at a different time.

In case of breach by the Bidder, the State may, without unreasonable delay, make a good faith effort to make a reasonable purchase or contract to purchased goods in substitution of those due from the Bidder. The State may recover from the Bidder as damages the difference between the costs of covering the breach. Notwithstanding any clause to the contrary, the State may also recover the contract price together with any incidental or consequential damages defined in UCC Section 2-715, but less expenses saved in consequence of Bidder's breach. OR In case of default of the Bidder, the State may contract the service from other sources and hold the Bidder responsible for any excess cost occasioned thereby.

The State's failure to make payment shall not be a breach, and the Bidder shall retain all available statutory remedies. (See Indemnity - Self-Insurance and Payment)

**J. NON-WAIVER OF BREACH**

Accept (Initial)	Reject (Initial)	Reject & Provide Alternative Response (Initial)	NOTES/COMMENTS:
AB			

The acceptance of late performance with or without objection or reservation by a Party shall not waive any rights of the Party nor constitute a waiver of the requirement of timely performance of any obligations remaining to be performed.

**K. SEVERABILITY**

Accept (Initial)	Reject (Initial)	Reject & Provide Alternative Response (Initial)	NOTES/COMMENTS:
AB			

If any term or condition of the contract is declared by a court of competent jurisdiction to be illegal or in conflict with any law, the validity of the remaining Terms and Conditions shall not be affected, and the rights and obligations of the parties shall be construed and enforced as if the contract did not contain the provision held to be invalid or illegal.

**INVITATION TO BID  
6750 OF**

**L. INDEMNIFICATION**

Accept (Initial)	Reject (Initial)	Reject & Provide Alternative Response (Initial)	NOTES/COMMENTS:
AB			

**1. GENERAL**

The Bidder agrees to defend, indemnify, and hold harmless the State and its employees, volunteers, agents, and its elected and appointed officials ("the indemnified parties") from and against any and all claims, liens, demands, damages, liability, actions, causes of action, losses, judgments, costs, and expenses of every nature, including investigation costs and expenses, settlement costs, and attorney fees and expenses ("the claims"), sustained or asserted against the State for personal injury, death, or property loss or damage, arising out of, resulting from, or attributable to the willful misconduct, negligence, error, or omission of the Bidder, its employees, Subcontractors, consultants, representatives, and agents, resulting from this contract, except to the extent such Bidder liability is attenuated by any action of the State which directly and proximately contributed to the claims.

**2. SELF-INSURANCE (Statutory)**

The State is self-insured for any loss and purchases excess insurance coverage pursuant to Neb. Rev. Stat. § 81-8,239.01 (Reissue 2008). If there is a presumed loss under the provisions of this contract, Bidder may file a claim with the Office of Risk Management pursuant to Neb. Rev. Stat. §§ 81-8,829 through 81-8,306 for review by the State Claims Board. The State retains all rights and immunities under the State Miscellaneous (Section 81-8,294), Tort (Section 81-8,209), and Contract Claim Acts (Section 81-8,302), as outlined in Neb. Rev. Stat. § 81-8,209 et seq. and under any other provisions of law and accepts liability under this contract to the extent provided by law.

**M. ATTORNEY'S FEES**

Accept (Initial)	Reject (Initial)	Reject & Provide Alternative Response (Initial)	NOTES/COMMENTS:
AB			

In the event of any litigation, appeal, or other legal action to enforce any provision of the contract, the Parties agree to pay all expenses of such action, as permitted by law and if ordered by the court, including attorney's fees and costs, if the other party prevails.

**N. ASSIGNMENT, SALE, OR MERGER**

Accept (Initial)	Reject (Initial)	Reject & Provide Alternative Response (Initial)	NOTES/COMMENTS:
AB			

Either party may assign the contract upon mutual written agreement of the other party. Such agreement shall not be unreasonably withheld.

The Bidder retains the right to enter into a sale, merger, acquisition, internal reorganization, or similar transaction involving Bidder's business. Bidder agrees to cooperate with the State in executing amendments to the contract to allow for the transaction. If a third party or entity is involved in the transaction, the Bidder will remain responsible for performance of the contract until such time as the person or entity involved in the transaction agrees in writing to be contractually bound by this contract and perform all obligations of the contract.

**INVITATION TO BID  
6750 OF**

**O. CONTRACTING WITH OTHER POLITICAL SUB-DIVISIONS OF THE STATE OR ANOTHER STATE**

Accept (Initial)	Reject (Initial)	Reject & Provide Alternative Response (Initial)	NOTES/COMMENTS:
AB			

The Bidder may, but shall not be required to, allow agencies, as defined in Neb. Rev. Stat. § 81-145, to use this contract. The Terms and Conditions, including price, of the contract may not be amended. The State shall not be contractually obligated or liable for any contract entered into pursuant to this clause.

The Bidder may, but shall not be required to, allow other states, agencies or divisions of other states, or political subdivisions of other states to use this contract. The Terms and Conditions, including price, of this contract shall apply to any such contract, but may be amended upon mutual consent of the Parties. The State of Nebraska shall not be contractually or otherwise obligated or liable under any contract entered into pursuant to this clause. The State shall be notified if a contract is executed based upon this contract.

**P. FORCE MAJEURE**

Accept (Initial)	Reject (Initial)	Reject & Provide Alternative Response (Initial)	NOTES/COMMENTS:
AB			

Neither party shall be liable for any costs or damages, or for default resulting from its inability to perform any of its obligations under the contract due to a natural or man-made event outside the control and not the fault of the affected party ("Force Majeure Event"). The Party so affected shall immediately make a written request for relief to the other party and shall have the burden of proof to justify the request. The other Party may grant the relief requested; relief may not be unreasonably withheld. Labor disputes with the impacted party's own employees will not be considered a Force Majeure Event.

**Q. CONFIDENTIALITY**

Accept (Initial)	Reject (Initial)	Reject & Provide Alternative Response (Initial)	NOTES/COMMENTS:
AB			

All materials and information provided by the Parties or acquired by a Party on behalf of the other Party shall be regarded as confidential information. All materials and information provided or acquired shall be handled in accordance with federal and state law, and ethical standards. Should said confidentiality be breached by a Party, the Party shall notify the other Party immediately of said breach and take immediate corrective action.

It is incumbent upon the Parties to inform their officers and employees of the penalties for improper disclosure imposed by the Privacy Act of 1974, 5 U.S.C. 552a. Specifically, 5 U.S.C. 552a (i)(1), which is made applicable by 5 U.S.C. 552a (m)(1), provides that any officer or employee, who by virtue of his/her employment or official position has possession of or access to Agency records which contain individually identifiable information, the disclosure of which is prohibited by the Privacy Act or regulations established thereunder, and who knowing that disclosure of the specific material is prohibited, willfully discloses the material in any manner to any person or Agency not entitled to receive it, shall be guilty of a misdemeanor and fined not more than \$5,000.00.

**R. EARLY TERMINATION**

Accept (Initial)	Reject (Initial)	Reject & Provide Alternative Response (Initial)	NOTES/COMMENTS:
AB			

The contract may be terminated as follows:

1. The State and the Bidder, by mutual written agreement, may terminate the contract at any time.



**INVITATION TO BID  
6750 OF**

- 2.** The State, at its sole discretion, may terminate the contract for any reason upon thirty (30) calendar day's written notice to the Bidder. Such termination shall not relieve the Bidder of warranty or other service obligations incurred under the terms of the contract. In the event of termination, the Bidder shall be entitled to payment, determined on a pro rata basis, for products or services satisfactorily performed or provided.
  
- 3.** The State may terminate the contract immediately for the following reasons:
  - a.** if directed to do so by statute;
  - b.** Bidder has made an assignment for the benefit of creditors, has admitted in writing its inability to pay debts as they mature, or has ceased operating in the normal course of business;
  - c.** a trustee or receiver of the Bidder or of any substantial part of the Bidder's assets has been appointed by a court;
  - d.** fraud, misappropriation, embezzlement, malfeasance, misfeasance, or illegal conduct pertaining to performance under the contract by its Bidder, its employees, officers, directors, or shareholders;
  - e.** an involuntary proceeding has been commenced by any party against the Bidder under any one of the chapters of Title 11 of the United States Code and (i) the proceeding has been pending for at least sixty (60) calendar days; or (ii) the Bidder has consented, either expressly or by operation of law, to the entry of an order for relief; or (iii) the Bidder has been decreed or adjudged a debtor;
  - f.** a voluntary petition has been filed by the Bidder under any of the chapters of Title 11 of the United States Code;
  - g.** Bidder intentionally discloses confidential information;
  - h.** Bidder has or announces it will discontinue support of the deliverable; and,
  - i.** In the event funding is no longer available.



**INVITATION TO BID  
6750 OF**

**III. BIDDER DUTIES**

**A. INDEPENDENT BIDDER / OBLIGATIONS**

Accept (Initial)	Reject (Initial)	Reject & Provide Alternative Response (Initial)	NOTES/COMMENTS:
AB			

It is agreed that the Bidder is an independent Bidder and that nothing contained herein is intended or should be construed as creating or establishing a relationship of employment, Agency, or a partnership.

The Bidder is solely responsible for fulfilling the contract. The Bidder or the Bidder's representative shall be the sole point of contact regarding all contractual matters.

The Bidder shall secure, at its own expense, all personnel required to perform the services under the contract. The personnel the Bidder uses to fulfill the contract shall have no contractual or other legal relationship with the State; they shall not be considered employees of the State and shall not be entitled to any compensation, rights, or benefits from the State, including but not limited to, tenure rights, medical and hospital care, sick and vacation leave, severance pay, or retirement benefits.

By-name personnel commitments made in the Bidder's bid shall not be changed without the prior written approval of the State. Replacement of these personnel, if approved by the State, shall be with personnel of equal or greater ability and qualifications.

The Bidder warrants that all persons assigned to the project shall be employees of the Bidder or a Subcontractor and shall be fully qualified to perform the work required herein. Personnel employed by the Bidder or a subcontractor to fulfill the terms of the contract shall remain under the sole direction and control of the Bidder or the subcontractor respectively.

With respect to its employees, the Bidder agrees to be solely responsible for the following:

1. Any and all pay, benefits, and employment taxes and/or other payroll withholding;
2. Any and all vehicles used by the Bidder's employees, including all insurance required by state law;
3. Damages incurred by Bidder's employees within the scope of their duties under the contract;
4. Maintaining Workers' Compensation and health insurance that complies with state and federal law and submitting any reports on such insurance to the extent required by governing law;
5. Determining the hours to be worked and the duties to be performed by the Bidder's employees; and,
6. All claims on behalf of any person arising out of employment or alleged employment (including without limit claims of discrimination alleged against the Bidder, its officers, agents, or subcontractors or subcontractor's employees).

If the Bidder intends to utilize any subcontractor, the Subcontractor's level of effort, tasks, and time allocation must be clearly defined in the Bidder's bid. The Bidder shall agree that it will not utilize any Subcontractors not specifically included in its bid in the performance of the contract without the prior written authorization of the State.

The State reserves the right to require the Bidder to reassign or remove from the project any Bidder or Subcontractor employee.

Bidder shall insure that the Terms and Conditions contained in any contract with a sub-contractor does not conflict with the Terms and Conditions of this contract.

The Bidder shall include a similar provision, for the protection of the State, in the contract with any Subcontractor engaged to perform work on this contract.

**B. EMPLOYEE WORK ELIGIBILITY STATUS**

The Bidder is required and hereby agrees to use a federal immigration verification system to determine the work eligibility status of employees physically performing work within the State. A federal immigration verification system means the electronic verification of the work authorization program authorized by the Illegal Immigration Reform and Immigrant Responsibility Act of 1996, 8 U.S.C. 1324a, known as the E-Verify Program, or an equivalent federal program designated by the United States Department of Homeland Security or other federal Agency authorized to verify the work eligibility status of an employee.

If the Bidder is an individual or sole proprietorship, the following applies:

1. The Bidder must complete the United States Citizenship Attestation Form, available on the DAS website at <http://das.nebraska.gov/materiel/purchasing.html>

The completed United States Attestation Form should be submitted with the solicitation response.

**INVITATION TO BID  
6750 OF**

2. If the Bidder indicates on such attestation form that he or she is a qualified alien, the Bidder agrees to provide the U.S. Citizenship and Immigration Services documentation required to verify the Bidder's lawful presence in the United States using the Systematic Alien Verification for Entitlements (SAVE) Program.
3. The Bidder understands and agrees that lawful presence in the United States is required, and the Bidder may be disqualified, or the contract terminated if such lawful presence cannot be verified as required by Neb. Rev. Stat. § 4-108.

**C. COMPLIANCE WITH CIVIL RIGHTS LAWS AND EQUAL OPPORTUNITY EMPLOYMENT / NONDISCRIMINATION (Statutory)**

The Bidder shall comply with all applicable local, state, and federal statutes and regulations regarding civil rights laws and equal opportunity employment. The Nebraska Fair Employment Practice Act prohibits Bidders of the State, and their Subcontractors, from discriminating against any employee or applicant for employment, with respect to hire, tenure, terms, conditions, compensation, or privileges of employment because of race, color, religion, sex, disability, marital status, or national origin (Neb. Rev. Stat. §§ 48-1101 through 48-1125). The Bidder guarantees compliance with the Nebraska Fair Employment Practice Act, and breach of this provision shall be regarded as a material breach of contract. The Bidder shall insert a similar provision in all Subcontracts for goods or services to be covered by any contract resulting from this solicitation.

**D. COOPERATION WITH OTHER BIDDERS**

Accept (Initial)	Reject (Initial)	Reject & Provide Alternative Response (Initial)	NOTES/COMMENTS:
AB			

Bidder may be required to work with or in close proximity to other Bidders or individuals that may be working on the same or different projects. The Bidder shall agree to cooperate with such other Bidders or individuals and shall not commit or permit any act which may interfere with the performance of work by any other Bidder or individual. Bidder is not required to compromise Bidder's intellectual property or proprietary information unless expressly required to do so by this contract.

**E. COST CLARIFICATION**

The State reserves the right to review all aspects of cost for reasonableness and to request clarification of any bid where the cost component shows significant and unsupported deviation from industry standards or in areas where detailed pricing is required.

**F. PERMITS, REGULATIONS, LAWS**

Accept (Initial)	Reject (Initial)	Reject & Provide Alternative Response (Initial)	NOTES/COMMENTS:
AB			

The contract price shall include the cost of all royalties, licenses, permits, and approvals, whether arising from patents, trademarks, copyrights or otherwise, that are in any way involved in the contract. The Bidder shall obtain and pay for all royalties, licenses, and permits, and approvals necessary for the performance of the contract. The Bidder must guarantee that it has the full legal right to the materials, supplies, equipment, software, and other items used to execute this contract.

**G. NOTICE OF POTENTIAL BIDDER BREACH**

Accept (Initial)	Reject (Initial)	Reject & Provide Alternative Response (Initial)	NOTES/COMMENTS:
AB			

If Bidder breaches the contract or anticipates breaching the contract the Bidder shall immediately give written notice to the State. The notice shall explain the breach or potential breach and may include a request for a waiver of the breach if so desired. The State may, at its discretion, temporarily or permanently waive the breach. By granting a temporary waiver, the State does not forfeit any rights or remedies to which the State is entitled by law or equity, or pursuant to the provisions of the contract. Failure to give immediate notice, however, may be grounds for denial of any request for a waiver of a breach.

**INVITATION TO BID  
6750 OF**

**H. ANTITRUST**

Accept (Initial)	Reject (Initial)	Reject & Provide Alternative Response (Initial)	NOTES/COMMENTS:
AB			

The Bidder hereby assigns to the State any and all claims for overcharges as to goods and/or services provided in connection with this contract resulting from antitrust violations which arise under antitrust laws of the United States and the antitrust laws of the State.

**I. CONFLICT OF INTEREST**

Accept (Initial)	Reject (Initial)	Reject & Provide Alternative Response (Initial)	NOTES/COMMENTS:
AB			

By submitting a bid, bidder certifies that no relationship exists between the bidder and any person or entity which either is, or gives the appearance of, a conflict of interest related to this ITB or project.

Bidder further certifies that bidder will not employ any individual known by bidder to have a conflict of interest nor shall bidder take any action or acquire any interest, either directly or indirectly, which will conflict in any manner or degree with the performance of its contractual obligations hereunder or which creates an actual or appearance of conflict of interest.

If there is an actual or perceived conflict of interest, bidder shall provide with its bid a full disclosure of the facts describing such actual or perceived conflict of interest and a proposed mitigation plan for consideration. The State will then consider such disclosure and proposed mitigation plan and either approve or reject as part of the overall bid evaluation.

**J. ADVERTISING**

Accept (Initial)	Reject (Initial)	Reject & Provide Alternative Response (Initial)	NOTES/COMMENTS:
AB			

The Bidder agrees not to refer to the contract award in advertising in such a manner as to state or imply that the company or its goods and services are endorsed or preferred by the State. Any publicity releases pertaining to the project shall not be issued without prior written approval from the State.

**K. NEBRASKA TECHNOLOGY ACCESS STANDARDS (Statutory)**

Bidder shall review the Nebraska Technology Access Standards, found at <http://nitc.nebraska.gov/standards/2-201.html> and ensure that products and/or goods provided under the contract are in compliance or will comply with the applicable standards to the greatest degree possible. In the event such standards change during the Bidder's performance, the State may create an amendment to the contract to request the contract comply with the changed standard at a cost mutually acceptable to the parties.

**L. DISASTER RECOVERY/BACK UP PLAN**

Accept (Initial)	Reject (Initial)	Reject & Provide Alternative Response (Initial)	NOTES/COMMENTS:
AB			

The Bidder shall have a disaster recovery and back-up plan, of which a copy should be provided upon request to the State, which includes, but is not limited to equipment, personnel, facilities, and transportation, in order to continue delivery of goods and services as specified under the specifications in the contract in the event of a disaster.

**INVITATION TO BID  
6750 OF**

**M. DRUG POLICY**

Accept (Initial)	Reject (Initial)	Reject & Provide Alternative Response (Initial)	NOTES/COMMENTS:
AB			

Bidder certifies it maintains a drug free workplace environment to ensure worker safety and workplace integrity. Bidder agrees to provide a copy of its drug free workplace policy at any time upon request by the State.

**N. WARRANTY**

Accept (Initial)	Reject (Initial)	Reject & Provide Alternative Response (Initial)	NOTES/COMMENTS:
AB			

Despite any clause to the contrary, the Bidder represents and warrants that its services hereunder shall be performed by competent personnel and shall be of professional quality consistent with generally accepted industry standards for the performance of such services and shall comply in all respects with the requirements of this Contract. For any breach of this warranty, the Bidder shall, for a period of ninety (90) days from performance of the service, perform the services again, at no cost to Customer, or if Bidder is unable to perform the services as warranted, Bidder shall reimburse Customer the fees paid to Bidder for the unsatisfactory services. The rights and remedies of the parties under this warranty are in addition to any other rights and remedies of the parties provided by law or equity, including, without limitation actual damages, and, as applicable and awarded under the law, to a prevailing party, reasonable attorneys' fees, and costs.

**INVITATION TO BID  
6750 OF**

**IV. PAYMENT**

**A. PROHIBITION AGAINST ADVANCE PAYMENT (Statutory)**

Neb. Rev. Stat. § 81-2403 states, "[n]o goods or services shall be deemed to be received by an Agency until all such goods or services are completely delivered and finally accepted by the Agency."

**B. TAXES (Statutory)**

The State is not required to pay taxes and assumes no such liability as a result of this solicitation. The Bidder may request a copy of the Nebraska Department of Revenue, Nebraska Resale or Exempt Sale Certificate for Sales Tax Exemption, Form 13 for their records. Any property tax payable on the Bidder's equipment which may be installed in a state-owned facility is the responsibility of the Bidder.

**C. INVOICES**

Invoices for payments must be submitted by the Bidder to the Agency requesting the services with sufficient detail to support payment. The Terms and Conditions included in the Bidder's invoice shall be deemed to be solely for the convenience of the parties. No terms or conditions of any such invoice shall be binding upon the State, and no action by the State, including without limitation the payment of any such invoice in whole or in part, shall be construed as binding or estopping the State with respect to any such term or condition, unless the invoice term or condition has been previously agreed to by the State as an amendment to the contract.

**D. INSPECTION AND APPROVAL**

Accept (Initial)	Reject (Initial)	Reject & Provide Alternative Response (Initial)	NOTES/COMMENTS:
AB			

Final inspection and approval of all work required under the contract shall be performed by the designated State officials. The State and/or its authorized representatives shall have the right to enter any premises where the Bidder or Subcontractor duties under the contract are being performed, and to inspect, monitor or otherwise evaluate the work being performed. All inspections and evaluations shall be at reasonable times and in a manner that will not unreasonably delay work.

**E. PAYMENT (Statutory)**

Payment will be made by the responsible Agency in compliance with the State of Nebraska Prompt Payment Act (See Neb. Rev. Stat. § 81-2403). The State may require the Bidder to accept payment by electronic means such as ACH deposit. In no event shall the State be responsible or liable to pay for any goods and services provided by the Bidder prior to the Effective Date of the contract, and the Bidder hereby waives any claim or cause of action for any such services.

**F. LATE PAYMENT (Statutory)**

The Bidder may charge the responsible Agency interest for late payment in compliance with the State of Nebraska Prompt Payment Act (See Neb. Rev. Stat. §§ 81-2401 through 81-2408).

**G. SUBJECT TO FUNDING / FUNDING OUT CLAUSE FOR LOSS OF APPROPRIATIONS (Statutory)**

The State's obligation to pay amounts due on the Contract for a fiscal year following the current fiscal year is contingent upon legislative appropriation of funds. Should said funds not be appropriated, the State may terminate the contract with respect to those payments for the fiscal year(s) for which such funds are not appropriated. The State will give the Bidder written notice thirty (30) calendar days prior to the effective date of termination. All obligations of the State to make payments after the termination date will cease. The Bidder shall be entitled to receive just and equitable compensation for any authorized work which has been satisfactorily completed as of the termination date. In no event shall the Bidder be paid for a loss of anticipated profit.

**H. RIGHT TO AUDIT (First Paragraph is Statutory)**

Accept (Initial)	Reject (Initial)	Reject & Provide Alternative Response (Initial)	NOTES/COMMENTS:
AB			

The State shall have the right to audit the Bidder's performance of this contract upon a thirty (30) day written notice. Bidder shall utilize generally accepted accounting principles, and shall maintain the accounting records, and other records and information relevant to the contract (Information) to enable the State to audit the contract. (Neb. Rev. Stat. § 84-304 et seq.) The State may audit, and the Bidder shall maintain the information during the term of the contract and for a period of five (5) years after the

**INVITATION TO BID  
6750 OF**

completion of this contract or until all issues or litigation are resolved, whichever is later. The Bidder shall make the Information available to the State at Bidder's place of business or a location acceptable to both Parties during normal business hours. If this is not practical or the Bidder so elects, the Bidder may provide electronic or paper copies of the Information. The State reserves the right to examine, make copies of, and take notes on any Information relevant to this contract, regardless of the form or the Information, how it is stored, or who possesses the Information. In no circumstances will Bidder be required to create or maintain documents not kept in the ordinary course of Bidder's business operations, nor will Bidder be required to disclose any information, including but not limited to product cost data, which is confidential or proprietary to Bidder.

The Parties shall pay their own costs of the audit unless the audit finds a previously undisclosed overpayment by the State. If a previously undisclosed overpayment exceeds two and one-half of one percent (2.5%) of the total contract billings, or if fraud, material misrepresentations, or non-performance is discovered on the part of the Bidder, the Bidder shall reimburse the State for the total costs of the audit. Overpayments and audit costs owed to the State shall be paid within ninety (90) days of written notice of the claim. The Bidder agrees to correct any material weaknesses or condition found as a result of the audit.

**INVITATION TO BID  
6750 OF**

**V. SCOPE OF WORK**

**A. SCOPE**

It is the intent of this bid to establish a contract to supply **Articulated AWD Loader with Minimum 3.8 CY Bucket** per the attached specifications from date of award for a period of One (1) year with the option to renew for an additional (four) One (1) year periods when mutually agreeable to the Bidder and the State. The State reserves the right to extend the period of this contract beyond the end date when mutually agreeable to the Bidder and the State.

All items proposed shall be of the latest manufacture in production as of the date of the solicitation and be of proven performance and under standard design complete as regularly advertised and marketed. All necessary materials for satisfactory performance of the supplies shall be incorporated into the **Articulated AWD Loader with Minimum 3.8 CY Bucket** whether or not they may be specifically mentioned below.

Complete specifications, manufacturer's current descriptive literature and/or advertising data sheets with cuts or photographs must be included with the bid for the IDENTICAL items proposed. Any information necessary to show compliance with these specifications not given on the manufacturer's descriptive literature and/or advertising data sheets must be supplied in writing on or attached to the bid document. If manufacturer's information necessary to show compliance with these specifications is not attached to the bid document, the Bidder may be required to submit requested information within three (3) business days of a written request. Failure to submit requested descriptive literature or advertising data sheets may be grounds to reject the bid.

**INVITATION TO BID  
6750 OF**

**VI. TECHNICAL SPECIFICATIONS**

**A. BIDDER INSTRUCTIONS**

Bidder must respond to each of the following statements. Specifications listed are minimum conditions that must be met in order for a Bidder to qualify for the award.

“YES” response means the Bidder guarantees they can meet this condition.

“NO” response means the Bidder cannot meet this condition and will not be considered.

“NO & PROVIDE ALTERNATIVE” responses should be used only with a narrative response in the “NOTES/COMMENTS” section explaining in detail any deviation from the Bidder’s ability to meet the condition, and an explanation of how this would be determined to be an acceptable alternative to meeting the condition. Alternatives must be detailed in such a way that allows such deviations to be fully evaluated. The State shall determine at its sole discretion whether or not the Bidder’s alternative is an acceptable alternative.

**\*\*\*ALL ITEMS IN THE FOLLOWING SPECIFICATIONS ARE REQUIREMENTS\*\*\***

**B. NON-COMPLIANCE STATEMENT**

YES	NO	NO & PROVIDE ALTERNATIVE	
✓			1. Read these specifications carefully.
✓			2. Any and all exceptions to these specifications must be written on or attached to solicitation response.
✓			3. Any noncompliance may void your bid. Non-compliance to any single specification can void your bid.
✓			4. It is the responsibility of Bidders to obtain information and clarifications as provided below.
✓			5. The State is not responsible for any erroneous or incomplete understandings or wrongful interpretations of this solicitation by any Bidder.
<b>NOTES/COMMENTS:</b>			

**C. ENGINE**

YES	NO	NO & PROVIDE ALTERNATIVE	
✓			1. Diesel engine shall be a minimum of 6.6 Liters.
✓			2. Engine shall have a minimum two hundred-twenty (220) net horsepower developed at SAE J1349 or ISO 9249 under standard conditions with all accessories.
✓			3. Cold starting aid of either glow plugs or equivalent pre-heater or ether injection of Turner LP535-1 or equivalent with cartridge.
✓			4. Manufacturer’s recommended muffler, alternator, and starter.
✓			5. Full flow, throw away type oil filter(s).
✓			6. Turbo II or Centri brand pre-cleaner or equivalent OEM supplied rotary ejection style pre-cleaner. Dual element air filtration is preferred.
✓			7. Heavy-duty radiator guard and crankcase guard.
✓			8. Engine housing side panels or tilt hood.
✓			9. Manufacturer’s recommended antifreeze protection to a minimum of thirty-four (34) degrees below zero Fahrenheit.
✓			10. A one hundred-twenty (120) volt AC block heater with a sturdily mounted male receptacle and cover that is conveniently located under cab chassis to be furnished in all water-cooled units.



**INVITATION TO BID  
6750 OF**

✓			11. Counter-balanced rain cap for exhaust preferred although Exhaust elbow is acceptable.
✓			12. Fuel Tank. <b>Specify fuel tank size in the "NOTES/COMMENTS" section below.</b>
✓			13. <b>Specify the Following:</b>
✓			a. Engine Brand: <b>FPT Engine</b>
✓			b. Engine Model: <b>F4HFE613R</b>
✓			c. Flywheel Horsepower: <b>224</b>
✓			d. Governed RPM: <b>2,000 RPM</b>
NOTES/COMMENTS: <b>⑫ 76 gallons</b> <b>⑬ Pre-Heater</b>			

**D. DRIVE**

YES	NO	NO & PROVIDE ALTERNATIVE	
✓			1. Torque converter/power shift with minimum four (4) speed forward and three (3) speed reverse transmission. Hydrostatic transmission is also acceptable.
✓			2. Inboard or outboard four (4) wheel planetary final reduction.
✓			3. Limited slip in front and/or rear differential required. Either front or rear differential lock-up are acceptable. <b>Specify item bidding in the "NOTES/COMMENTS" section below.</b>
✓			4. Minimum forward travel speed will be approximately twenty (20) MPH.
NOTES/COMMENTS: <b>Limited Slip Front + Rear</b>			

**E. TIRES AND WHEELS**

YES	NO	NO & PROVIDE ALTERNATIVE	
✓			1. Four (4) 23.5R25, Michelin XTLA.
NOTES/COMMENTS:			

**F. BRAKES**

YES	NO	NO & PROVIDE ALTERNATIVE	
✓			1. Brakes on all four (4) wheels.
✓			2. Brakes shall be boosted, full hydraulic type or air brakes. <b>Specify type of brakes bid in the "NOTES/COMMENTS" section below.</b>
✓			3. Air dryer or equivalent moisture remover required with air brakes.
✓			4. Transmission drive or internal wet disk service brakes acceptable.

**INVITATION TO BID  
6750 OF**

✓		5. Parking brake required.
NOTES/COMMENTS: <i>Hydraulically Activated, maint. free, multiple wet Disk w/ accumulator to all four wheels</i>		

**G. STEERING**

YES	NO	NO & PROVIDE ALTERNATIVE	
✓			1. Articulated frame at wheelbase center point.
✓			2. Turn to right and left of at least forty (40) degrees.
✓			3. To be hydraulically assisted.
NOTES/COMMENTS:			

**H. LOADER**

YES	NO	NO & PROVIDE ALTERNATIVE	
✓			1. Static full turn tipping load must be a minimum of 24,500 pounds.
✓			2. Joystick control.
✓			3. General purpose loader bucket to be minimum 3.8 CY struck SAE rated.
✓			4. Bucket shall be minimum one hundred ten inches (110") wide but not less than the overall width of the machine.
✓			5. Dump clearance at full lift with bucket at forty-five (45) degrees discharge shall be at least nine feet (9'), three inches (3").
✓			6. Minimum 33,500-pound breakout force.
✓			7. Digging depth of at least 2.9 inches below grade with bucket bottom approaching position parallel to grade.
✓			8. Bucket level indicator or automatic pre-set to dig position and adjustable automatic lift kick out required. Bucket shall have a bolt-on cutting edge.
✓			9. Z-bar linkage or parallel Lift Linkage will be acceptable.
✓			10. Loader shall be equipped with a suspension system for the loader boom cylinders. Ride Control/Suspension System to include any accumulators, valves, hydraulic lines and/or electrical circuits as required by the manufacturer.
NOTES/COMMENTS:			

**I. CAB**

YES	NO	NO & PROVIDE ALTERNATIVE	
✓			1. The ROPS cab shall be of steel construction:
✓			a. Cab shall be fully and tightly enclosed with sound suppression.
✓			b. Tinted safety glass windshield, windows and door(s) required.
✓			2. Cab to be equipped with mounting ladder:

**INVITATION TO BID  
6750 OF**

✓			a. Electric windshield wipers with washers both front and rear;
✓			b. Inside rear-view mirror(s) and floor mat required;
✓			c. Standard AM/FM radio installed;
✓			d. Defroster fan and heater of adequate capacity for cab required;
✓			e. Unit shall have manufacturer's factory installed air conditioning;
✓			f. Unit to have rearview camera installed; and
✓			g. Loader must be able to be operated with door(s) secured open.
✓			3. Padded adjustable, cloth covered suspension seat with seat belt shall be provided.
<b>NOTES/COMMENTS:</b>			

**J. INSTRUMENTS**

YES	NO	NO & PROVIDE ALTERNATIVE	
✓			<b>1. The following gauges or digital displays are required:</b>
✓			a. Air pressure gauge if air brakes;
✓			b. Torque converter or transmission oil temperature gauge;
✓			c. Fuel gauge or indicator;
✓			d. Oil pressure gauge;
✓			e. Engine temperature gauge; and
✓			f. Voltmeter, ammeter, or warning light for the twelve (12) or twenty-four (24) volt system.
✓			<b>2. Audible and visible alarm system for high engine temperature, low oil pressure and high transmission oil temperature.</b>
✓			<b>3. An electronic, back-up alarm meeting OSHA requirements to be provided.</b>
<b>NOTES/COMMENTS:</b>			

**K. HYDRAULIC SYSTEM**

YES	NO	NO & PROVIDE ALTERNATIVE	
✓			<b>1. Constantly driven, gear, piston, or vane type pump.</b>
✓			<b>2. Replaceable system filters and pressure relief valve.</b>
✓			<b>3. System operation pressure shall be a maximum of three thousand eight hundred (3,800) PSI.</b>

**INVITATION TO BID  
6750 OF**

<input checked="" type="checkbox"/>			4. Third Valve with all controls, lines, fittings, and couplers to front of loader boom for attachments.
NOTES/COMMENTS:			

**L. COUNTERWEIGHTS**

YES	NO	NO & PROVIDE ALTERNATIVE	
<input checked="" type="checkbox"/>			1. Standard equipment rear counterweights.
NOTES/COMMENTS:			

**M. GENERAL**

YES	NO	NO & PROVIDE ALTERNATIVE	
<input checked="" type="checkbox"/>			1. The overall length of the loader will not be greater than twenty-seven feet (27'), five inches (5'), with loader bucket level on the ground.
<input checked="" type="checkbox"/>			2. The operation weight of loader with minimum 3.8 CY bucket, ROPS cab and without optional accessories or calcium chloride in tires shall be a minimum of forty thousand (40,000) pounds. <b>Specify loader weight in pounds in the "NOTES/COMMENTS" section below.</b>
<input checked="" type="checkbox"/>			3. Four (4) LED headlights two (2) at top of cab near corners and two (2) at bottom of cab near each side).
<input checked="" type="checkbox"/>			4. One (1) rear working LED light.
<input checked="" type="checkbox"/>			5. Combination LED stop/taillight and horn.
<input checked="" type="checkbox"/>			6. Drawbar hitch with pin.
<input checked="" type="checkbox"/>			7. Turn signal and hazard flashing LED lights for front and rear.
<input checked="" type="checkbox"/>			8. Manufacturer's front and rear fenders required.
<input checked="" type="checkbox"/>			9. <b>A slow-moving vehicle emblem shall be mounted on the rear of loader and displayed as required per Neb. Rev. Stat. § 60-6241.</b>
<input checked="" type="checkbox"/>			a. Emblem shall be mounted so as not to restrict airflow for cooling purposes.
NOTES/COMMENTS: ② 45,070 lbs			

**N. NOISE LEVEL**

YES	NO	NO & PROVIDE ALTERNATIVE	
<input checked="" type="checkbox"/>			1. Bidder should supply with bid the following decibel level per SAE Standards. <b>Specify sound exposure work cycle rating dba in the "NOTES/COMMENTS" section below.</b>
NOTES/COMMENTS: ① 69 DBA			

**INVITATION TO BID  
6750 OF**

**O. RADIO FREQUENCY SHIELDING – CAUTION!!!**

YES	NO	NO & PROVIDE ALTERNATIVE	
✓			1. The loader and/or installed components and equipment shall be compatible with use of NDOT mobile and/or two-way communication devices. Main communication radio operates in low band range of forty-seven (47) MHz to forty-eight (48) MHz, but all frequencies apply including low band, high band, UHF, and VHF.
✓			2. The loader and/or installed components and equipment shall be manufactured to meet all current SAE and/or ISO Standards applicable and/or relevant to electromagnetic Compatibility.
✓			3. NDOT will conduct testing of radio/two-way when installed in chassis.
✓			4. NDOT will notify bidder if normal operational parameters are not met due to degradation of signals caused by electromagnetic emissions from chassis or installed components and equipment.
✓			5. Bidder shall be required to work with NDOT personnel to reduce interference level to a point acceptable to NDOT normal radio operating parameters.
✓			6. Bidder shall have thirty (30) days to resolve radio frequency issue.
✓			7. Bidder and/or manufacturer will be responsible for any and all cost to replace and/or modify any parts found to cause radio frequency interference.
✓			8. If NDOT and awarded bidder cannot resolve source of radio frequency issue the unit will be sent to an independent accredited lab for testing to ensure SAE and/or ISO Standards compliance.
✓			9. Testing shall be done to SAE and/or ISO Standards which are current at date of bid.
✓			10. Should the loader and/or installed components and equipment fail testing at the accredited lab, the awarded bidder shall be responsible for all cost incurred for testing.
✓			11. If after testing by NDOT and/or accredited lab, the awarded bidder is unable or unwilling to incur the cost and correct the radio frequency issue to the satisfaction of NDOT, all orders and corresponding contract will be canceled.
<b>NOTES/COMMENTS:</b>			

**P. MANUALS**

YES	NO	NO & PROVIDE ALTERNATIVE	
✓			1. <b>All manuals, whether for core or optional items, shall accompany each unit upon delivery.</b>
✓			2. <b>The following Manuals or CD ROMs should accompany each unit upon delivery:</b>
✓			a. Operator's Manual or CD ROM
✓			b. Equipment Shop Repair Manual or CD ROM
✓			c. Engine Shop Repair Manual or CD ROM
✓			d. Equipment Parts Manual or CD ROM
✓			e. Engine Parts Manual or CD ROM
✓			3. If the above-mentioned Manuals are available online the State must be able to access them free of charge for fifteen (15) years.

**INVITATION TO BID  
6750 OF**

✓			4. All manuals should be furnished upon delivery. Per Neb. Rev. Stat. 81-2403 Goods or service; payment in full; when required (3) "no goods or services shall be deemed to be received by an agency until all such goods or services are completely delivered and finally accepted by the agency...". Thus, payment will not be made until the unit and all required documents are received.
NOTES/COMMENTS:			

**Q. MISCELLANEOUS**

YES	NO	NO & PROVIDE ALTERNATIVE	
✓			1. The bidders should submit with their bid a list of any special tools they will furnish with each unit.
✓			2. Dealer's decals, stickers or other signs shall not be affixed to units.
✓			3. Dealer's pre-delivery service required.
✓			4. Manufacturer's standard yellow color.
✓			5. Prior to the awarding of, or entering into any agreement or contract, it shall be the responsibility of the manufacturer and/or the successful bidder to warrant to the State of Nebraska, in writing, that it has factory authorized dealers in the State of Nebraska who will provide warranty/service and repair work without undue delay.
NOTES/COMMENTS:			

**R. TRAINING**

YES	NO	NO & PROVIDE ALTERNATIVE	
✓			1. Minimum of four (4) hours per loader at various locations throughout Nebraska by a factory trained representative in the operation and maintenance of loader. Fleet Management will contact awarded bidder on schedule and places for this training.
NOTES/COMMENTS:			

**S. SPECIFICATION FORM(S)**

YES	NO	NO & PROVIDE ALTERNATIVE	
✓			1. Specification form(s) will be supplied by NDOT to the awarded bidder after a purchase order has been issued. The awarded bidder will be required to fully complete the specification form(s) possible for each unit and must accompany each unit when delivered.

**INVITATION TO BID  
6750 OF**

✓			2. if bidder does not properly complete required form(s) for each unit, per Neb. Rev. Stat. 81-2403 Goods or service; payment in full; when required (3) "no goods or services shall be deemed to be received by an agency until all such goods or services are completely delivered and finally accepted by the agency....". Thus, payment will not be made until the unit and all required form(s) are received.
NOTES/COMMENTS:			

**T. ANNUAL USAGE, ESTIMATED**

YES	NO	NO & PROVIDE ALTERNATIVE	
✓			1. Annual usage figures provided are estimates and are not to be construed as either a minimum or maximum purchase quantity.
✓			2. The orders shall be for the actual quantities of each item ordered by or for any agency during the life of the contract.
✓			3. Bidder shall not impose minimum order requirements.
✓			4. The estimated annual usage of the Articulated AWD Loader with Minimum 3.8 CY Bucket is two (2) each.
NOTES/COMMENTS:			

**U. USAGE REPORT**

YES	NO	NO & PROVIDE ALTERNATIVE	
✓			1. The bidder shall, upon request at any time by the State as determined by the State, provide a usage report of this contract by state agencies and political subdivisions. Information will include, but is not limited to, agency/political subdivision name, item name, item number and dollar amount.
NOTES/COMMENTS:			

**V. DELIVERY ARO**

YES	NO	NO & PROVIDE ALTERNATIVE	
		210-300 days	1. Delivery desired within one hundred twenty (120) to two hundred (200) days ARO.
			2. If ARO will be different than one hundred twenty (120) to two hundred (200) days ARO specify alternative in the "NOTES/COMMENTS" section below.
✓			3. Not meeting the desired ARO stated in line one (1) of this section can be an award consideration.
NOTES/COMMENTS: 210-300 days - Delivery could be sooner depending on product manufacturing delays/improvements			

**INVITATION TO BID  
6750 OF**

**W. DELIVERY LOCATION**

YES	NO	NO & PROVIDE ALTERNATIVE	
✓			1. NDOT 5001 S 14 <sup>th</sup> Street Lincoln, NE 68512
NOTES/COMMENTS:			

**X. ORDERS**

YES	NO	NO & PROVIDE ALTERNATIVE	
✓			1. Orders will be placed by e-mail. To the awarded bidder.
✓			2. All orders must reference a purchase order number.
✓			3. The purchase order number must be referenced on the packing slip, and invoice.
✓			4. Invoices are to be sent to the "Invoice to" address on the purchase order.
NOTES/COMMENTS:			

**Y. QUALITY**

YES	NO	NO & PROVIDE ALTERNATIVE	
✓			1. Product quality must meet specifications and be consistent for the term of the contract. All materials must be of first quality, under standard production by the manufacturer and be of standard design, complete as regularly advertised and marketed and be of proven performance.
✓			2. A guarantee of satisfactory performance by the Bidder and meeting delivery dates are an integral part of the purchase contract resulting from this ITB.
✓			3. Products are to be fully guaranteed and may be returned for full credit or replacement (at the State's option) for any reason during the initial warranty period with no additional charges for shipping or restocking.
NOTES/COMMENTS:			

**Z. WARRANTY**

YES	NO	NO & PROVIDE ALTERNATIVE	
✓			1. Manufacturer's usual warranty shall apply and shall be in effect for at least one (1) year from the date the equipment was placed in service by purchasing entity.
			2. Bidder should supply warranty information with bid.
✓			3. Bidder shall be responsible for all repairs to include parts, labor, and machine transportation cost during the twelve (12) month usual warranty period.
✓			4. The power train and engine shall be warranted for additional five (5) years.



**INVITATION TO BID  
6750 OF**

✓			<b>5. These guarantees are in addition to the standard twelve (12) month warranty and do not have any effect upon the standard warranty.</b>
✓			<b>a.</b> If the engine is not produced by the loader manufacturer, the bidder will guarantee that the engine will be repaired by a certified and registered engine warranty dealer or distributorship.
✓			<b>6. The following power train components are warranted to be free from defects in workmanship and material during the extended warranty period:</b>
✓			<b>a.</b> Engine (excluding radiator, alternator, starter, compressor, and other attachments).
✓			<b>b.</b> Torque converter (if applicable), transmission.
✓			<b>c.</b> Drive shafts and Universal joints.
✓			<b>d.</b> Differential.
✓			<b>e.</b> Transfer gear group.
✓			<b>f.</b> Drive axles.
✓			<b>g.</b> Drive pumps.
✓			<b>h.</b> Drive motors.
✓			<b>i.</b> Pinion and bevel gear.
✓			<b>j.</b> Final drive gear train.
✓			<b>k.</b> Computerized and electronic equipment.
✓			<b>7.</b> This warranty is limited to repair or replacement (including both parts and labor) of inspected parts determined to have been defective in material or workmanship.
✓			<b>8.</b> All extended power train warranty repairs will be performed by manufacturer's authorized service personnel.
✓			<b>9.</b> All machine transportation costs to and from the nearest authorized repair facility, travel time, and mileage during the extended warranty period will be the responsibility of the awarded bidder and/or manufacturer.
✓			<b>10.</b> This warranty does not apply to normal maintenance service (such as engine tune-up) or normal replacement of service or wear items.
✓			<b>11.</b> Any oil sampling or other necessary testing needed to implement this warranty must be included in writing with this bid.
✓			<b>12.</b> NDOT will do oil sampling, but all materials must be furnished by the awarded bidder.
✓			<b>13.</b> A written report will be returned to NDOT if sampling is required.
			<b>14. This extended coverage is subject to the following conditions and limitations:</b>
✓			<b>a.</b> Replacement parts provided are warranted for the remainder of the extended warranty period applicable to the product in which installed.
✓			<b>b.</b> The machine may not be altered or modified in any manner which affects the mechanical operation as designed with written permission from NDOT.
			<b>15. The following limitations shall be applicable to all guarantees:</b>
✓			<b>a.</b> Parts ordering and machine repair requests will occur during the awarded bidder's normal working hours.
✓			<b>b.</b> The parts and machine repair guarantees will not apply to machines which have been substantially damaged by collision, accident, flood, fire, vandalism, or similar occurrence.
✓			<b>16.</b> If machine cannot be repaired within thirty (30) days, a comparable loaner machine will be furnished to NDOT at no cost during the warranty period.
<b>NOTES/COMMENTS:</b>			

**INVITATION TO BID  
6750 OF**

**AA. AUTHORIZED DEALER & WARRANTY**

YES	NO	NO & PROVIDE ALTERNATIVE	
✓			1. To the extent required by the manufacturer, the Bidder shall be an authorized dealer. The awarded bidder may be required to substantiate that they are an authorized dealer.
✓			2. Proof of being an authorized dealer, if required, must be submitted to SPB within three (3) business days of the request and prior to the award of any contract.
✓			3. The terms of the original manufacturer's standard warranty shall apply to all equipment acquired from this bid for the entire warranty period.
✓			4. Bidder shall provide a list of approved OEM service, repair & parts locations in the State of Nebraska or within a four (4)-hour response time. <b>Provide this information in the "NOTES/COMMENTS" section below or attach list</b>
✓			5. Bidder shall provide a list of approximate number and locations of OEM Trained and certified service technicians in the state of Nebraska or within a four (4)-hour response time. <b>Locations can be listed in the "NOTES/COMMENTS" section below or a document listing the locations can be submitted as a separate attachment.</b>
<p><b>NOTES/COMMENTS:</b>      <i>See attached List</i></p>			

**INVITATION TO BID  
6750 OF**

**VII. OPTIONS**

**A. QUICK HITCH WITH SPECIFIED BUCKET**

YES	NO	NO & PROVIDE ALTERNATIVE	
✓			1. Quick hitch (coupler) system with bucket equivalent to bucket specified in Section VI, Subsection H-LOADER.
✓			2. The manufacturer's loader and the factory bucket will be replaced by the quick hitch and bucket.
✓			3. Acceptable brands are JRB, ACS or loader manufacturer's model. Please specify which brand you are bidding in the "NOTES/COMMENTS" section below.
✓			4. The securing pins controls in the cab will hydraulically operate from loader's existing hydraulics.
✓			5. Quick hitch and specified bucket must be recommended by the manufacturer for the loader bid.
<p>NOTES/COMMENTS: <span style="margin-left: 100px;">JRB 418</span></p>			

**B. QUICK ATTACH FORKLIFT ASSEMBLY**

YES	NO	NO & PROVIDE ALTERNATIVE	
✓			1. Forklift assembly to be quick attach style and match the quick hitch with specified bucket.
✓			2. Quick hitch shall be JRB, ACS or loader manufacturer OEM supplied hitch.
✓			3. Carriage width to be minimum fifty-three inches (53").
✓			4. Tine length to be minimum sixty inches (60").
✓			5. Manually adjustable tines of two and one-half inch (2.5") X six inch (6").
✓			6. Minimum Load Capacity of 10,000 pounds at twenty-four-inch (24") load center.
<p>NOTES/COMMENTS:</p>			

**C. MULTI-PURPOSE BUCKET**

YES	NO	NO & PROVIDE ALTERNATIVE	
✓			1. The factory furnished bucket will be replaced by a multi-purpose bucket.
✓			2. The multi-purpose bucket shall be at a minimum as heavy duty as the manufacturer's loader normally furnished bucket.
✓			3. Any additional valves, hydraulics, hoses, etc. will be furnished by awarded bidder.
✓			4. The unit for the loader bucket shall be as recommended by the manufacturer.
<p>NOTES/COMMENTS:</p>			

**INVITATION TO BID  
6750 OF**

**D. GRAPPLE FORK ATTACHMENT**

YES	NO	NO & PROVIDE ALTERNATIVE	
✓			1. Grapple fork to GrabTec "GA" series or equivalent to be mounted to bucket as specified in Section VI, Subsection H-LOADER.
✓			2. Grapple fork is to be installed on the bucket.
✓			3. Any costs incurred, including any transportation costs, to have the grapple fork mounted to the specified bucket shall be the responsibility of the awarded bidder.
✓			4. <b>Grapple assembly to be of a Quick Attach Style:</b>
✓			a. Install weight of grapple assembly to be minimum twelve hundred (1,200) pounds.
✓			b. Hydraulic cylinder bore to be a minimum three inches (3").
✓			c. Hydraulic hoses of adequate length with couplers for accessory attachments shall be coupled to the loader's auxiliary circuit (Third Valve)
✓			d. Fork teeth material to be minimum one inch (1") thick.
✓			e. A minimum of five (5) replaceable Fork teeth per assembly.
✓			f. Clamping force of fork assembly to be approximately ten thousand (10,000) pounds rated with cylinder pressure of three thousand seven hundred fifty (3,750) PSI.
✓			g. Opening of forks measured from ground level to tip of teeth to be approximately eighty-six inches (86").
✓			5. Any additional hydraulic valve hoses, excluding the auxiliary third valve, etc. to be furnished by the awarded bidder.
✓			6. Attachment shall carry a one (1) year warranty to be provided by the fork manufacturer or by the awarded bidder.
<b>NOTES/COMMENTS:</b>			

**E. WHEEL LOADER SCALE SYSTEM**

YES	NO	NO & PROVIDE ALTERNATIVE	
✓			1. Scale system to be Loup Electronics Weighlog 8000T or equivalent and shall be installed and calibrated on loader.
✓			2. Optional in-cab printer.
✓			3. Hydraulic pressure sensors.
✓			4. Reference and direction sensor.
<b>NOTES/COMMENTS:</b>			



**CASE**  
CONSTRUCTION  
SINCE 1842

**G SERIES**  
**WHEEL LOADERS**

521G | 621G | 721G | 821G | 921G | 1021G | 1121G



# THE MOST IMPORTANT CYCLE

Every CASE G Series wheel loader is built on uptime and new ways to simplify operation to give you more performance and productivity that turns uptime into profitability.

*That* is the most important cycle you run.

From lower total cost of ownership (TCO) and new ways to collaborate on fleet management, to the core truths of fuel efficiency, operator comfort and reliability in the most intense environments — CASE G Series wheel loaders deliver everything you need to get it all done.

New enhancements include:

- + **Simplify operation and centralize control with the all-new touchscreen display**
- + **Program your most commonly used settings and activate functions quicker with new configurable buttons**
- + **Independently set lift (boom) and tilt (bucket) performance to smooth, moderate or aggressive with new adjustable electro-hydraulic controls**
- + **Simplify operation with two power modes: Max and Smart. Max is for working all-out. Smart delivers high performance, smoother shifting, reduced tire wear and greater fuel efficiency**
- + **Greater material retention and performance with electro-hydraulic parallel lift\***
- + **Improve load accuracy and reporting, and simplify acquisition, with a new fully integrated factory-built payload system\*\***
- + **Greater connectivity improves telematics reporting, allows for remote diagnostics and software updates, and encourages powerful fleet management collaboration**

\*Z-bar and XR configurations.

\*\*Optional.







**LINKAGE FOR EVERY APPLICATION**

CASE G Series wheel loaders offer numerous front linkage options, dependent on model: Z-bar, XR (extended reach) and XT\* (tool carrier).



\*Available on the 521G through 721G.



# PRACTICAL INNOVATION. EASIER OPERATION.



## A NEW STANDARD IN OPERATION

Access all critical machine settings and operational data through an all-new touchscreen display — as well as the optional rearview camera, the all-new optional integrated payload system, and the all-new Tire Pressure Monitoring System (TPMS).



## CUSTOMIZED SETTINGS AND FUNCTIONS

Three new color-coded, configurable buttons on the armrest allow for quick and easy changes between settings and functions, such as engaging the rearview camera, engaging differential lock\*, or accessing the integrated payload system. The three configurable buttons are then set to three different tasks or functions when working with the payload system.



## INDEPENDENTLY CONTROL LIFT/TILT

Set lift (boom) and tilt (bucket) responsiveness to smooth, moderate or aggressive depending on the job or operator preference with new adjustable electro-hydraulic controls.

**Pro Tip:** The aggressive control on the bucket is perfect for feathering/metering in material as you top off hoppers or trucks, or cleaning out stubborn material stuck inside the bucket.



## GET PARALLEL (IN ALL CONFIGURATIONS)

The new electro-hydraulic parallel lift feature (available on Z-bar and XR configurations) gives you the steady load-and-carry performance of a tool carrier across all configurations in the CASE G Series lineup (XT configurations provide mechanical self leveling).

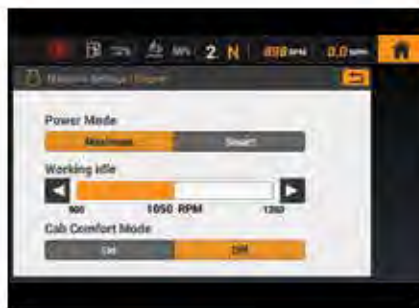

## OPERATE HOW YOU WANT

Power modes have been simplified from four down to two - Max and Smart. Max for when you need to go all out. Smart for improved fuel efficiency and reduced tire wear (without sacrificing performance).



## KEEP INFLATED

Help ensure uptime and performance with properly inflated tires and the all-new Tire Pressure Monitoring System (TPMS). Proper tire inflation improves machine responsiveness and operator comfort, improves fuel economy, and reduces wear and tear on your tires. The system alerts operators and fleet management staff when tire inflation falls outside the desired range.

\*\*When equipped.



# ENJOY THE RIDE

Big power that rides easy — CASE G Series wheel loaders offer one of the industry's most comfortable and adjustable workstations matched with sweeping glass windows for extreme comfort and visibility.

**Pro Tip:** Get the Enhanced Visibility Package that bundles rearview camera, LED lights and heated mirrors for even greater visibility.



## GET COMFORTABLE

Multiple ergonomic seat options with controls and armrests that move both with and independently of the seat.



## RUN EASY

Simple ergonomic controls and joysticks reduce operator fatigue and make long days at the wheel a breeze.



## DIAL IT IN

The membrane keypad controls multiple machine functions in easy reach of the operator, including programmable height control, return-to-dig, and the new electro-hydraulic parallel lift function.



## SEE IT ALL

Greater visibility to all sides of the machine is achieved with a one-piece rounded windshield, a rear grid defroster, and external mirrors optimally placed to prevent operator fatigue. The optional rearview camera further improves operator awareness and confidence.



# HOW WE EARNED YOUR TRUST

CASE G Series wheel loaders run every yard and pit with extreme fuel efficiency, lower operating temperatures, excellent power and productivity — along with a reputation for standing up to the toughest conditions. The proof:



## SIPPIN' FUEL

Patented Tier 4 Final SCR engine technology meets emissions standards while maximizing fuel efficiency and performance — all while keeping engine compartment temperatures down with no DPF and no regen.



## RUN COOL

The Mid-Mounted Cooling Module (521G-921G) provides greater rear visibility and pushes the engine back for greater counterweight, and the CASE Cooling Cube (1021G-1121G) keeps the engine cool with excellent access to all coolers.



## LIGHT IT UP

An LED light package with two front drive lights, four front working lights and two rear working lights - along with standard integrated four-corner strobes - helps operators see and be seen in all operations.



## KEEP IT ALL

Standard Ride Control provides excellent material retention and control over rough terrain, while reducing shock loads on the machine and operator.



## DRIVE ANY SITE

CASE G Series wheel loaders feature a number of axle options to match the type of conditions and terrain you run on, including standard limited-slip front (521G-821G) and rear, auto locking front, and conventional or open rear.



## SHORTEN CYCLE TIMES

The optional five-speed PowerShift transmission with lock-up torque converter (621G-921G) provides faster acceleration and roading speeds up to 25 mph. And Powerinch provides incredible accuracy and control in tight loading areas, regardless of engine speed or grade.



# UPTIME. CONNECTED.

Greater connectivity improves telematics performance, allows for remote diagnostics and software updates, and makes CASE and your local dealer the most powerful fleet management partners you have.



## THE CASE UPTIME CENTER

CASE technical experts monitor telematics data from your equipment\* to provide even more support and analysis to your operation. CASE and your local dealer service teams will work together as a powerful extension of your own fleet management activities to proactively identify possible issues with operation and performance, work together on solutions, and provide you with the support you need to optimize your uptime.

## SiteConnect Module Onboard

The new SiteConnect Module improves the volume, flow and integration of data to the CASE SiteWatch telematics platform — and makes remote diagnostics, code clearing and software updates possible. When you see this symbol on CASE equipment, you know you're connected.



## CASE | SiteWatch

The all-new CASE SiteWatch telematics platform delivers a new and intuitive dashboard, simplified navigation and practical reporting capabilities that improve everything from preventive maintenance and fleet health to employee productivity. The connectivity of the SiteConnect Module allows for new reporting and ticketing with payload systems, new alerts for Tire Pressure Monitoring Systems (TPMS) and more, and a greater flow of information to fleet management partners such as CASE and your local CASE dealer.



## CASE | SiteManager

The CASE SiteManager App (iOS and Android) helps make quick work of downtime by allowing your CASE dealer to have remote access to your machine, diagnose a problem, clear codes and, if needed, provide a quick software update. If a field visit is required, the dealer tech arrives on site with the parts and tools needed to get that machine up and running quicker.

**Pro Tip:** The purpose-built, factory integrated system allows for payload functionality to be added to your fleet without requiring separate financing, acquisition and installation — the system is entirely turnkey.

\*When agreed to by the equipment owner.



# MAKE WEIGHT. EVERY TIME.

The all-new optional CASE G Series payload system is integrated directly into the loader's primary display and provides bucket weight, pass counts, accumulated/running weight, job tracking data and more for high-volume loading and production environments. This allows operators to precisely load each truck to reduce under/overload situations, and cumulatively track the total weight of material loaded into each truck. It also helps operators track total loads and total volume of material moved over a period of time, and can also track history by customer, truck, or material, as well as provide ticket histories.



## IN PITS AND QUARRIES

Cut down on topping off trucks at the scale and situations where trucks have to dump material because they are overweight, or drive to a site underloaded because the operator was light with each bucket.



## IN GENERAL CONSTRUCTION

Keep track of the amount of material loaded off of each site, and ensure that your trucks are in compliance with local weight restrictions.



## IN AGRICULTURAL OPERATIONS

The payload system serves as another proof point/check on measurements, such as the amount of lime being applied to a field, or the amount of ingredients applied to a feed mix.

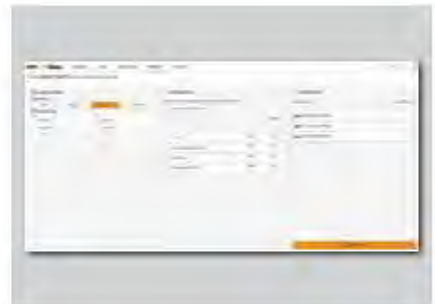

## SITEWATCH INTEGRATION

SiteWatch enables full integration with the all-new payload system to provide payload reports, ticket details and overall performance information.



# INDUSTRY-LEADING GROUNDLINE ACCESS

## WE MAKE MAINTENANCE SIMPLE

G Series wheel loaders feature an electric rear hood lift\* that provides easy access to the engine compartment for excellent groundline serviceability. All major regular service points can be accessed from ground level, meaning daily maintenance can be completed in a matter of minutes.





## NO TOOLS NEEDED

The G Series continues the CASE hallmark of simple serviceability with features like tool-free access to the oil cooler, radiator and other routine maintenance points.

## EASY ACCESS TO EVERYTHING

- 1 Engine filter
- 2 Electric rear hood lift\*
- 3 Mid-Mounted Cooling Module (1021G and 1121G feature the CASE Cooling Cube)
- 4 Hydraulic tank site gauge
- 5 Grouped grease points
- 6 Jump-start posts
- 7 Environmental drain ports
- 8 HVAC fresh air filter and recirculation air filter
- 9 Fuel/DEF fill
- 10 Engine oil check and fill
- 11 Tire Pressure Monitoring System (TPMS)

\*Available on 621G-1121G models

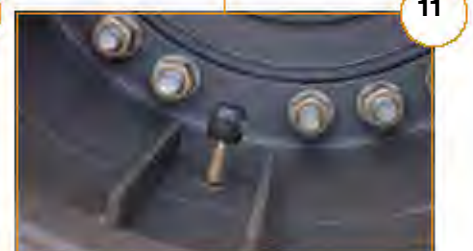
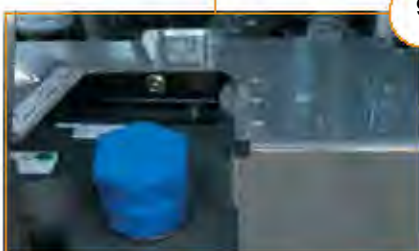

Protected by  
**ProCare**

**FACTORY WARRANTY**  
**PLANNED MAINTENANCE**  
**TELEMATICS**



**3-yr/3000-hr**  
**Full-Machine Factory**  
**Limited Warranty\***  
**STANDARD**



**3-yr/2000-hr**  
**Planned Maintenance**  
**STANDARD**



**3-yr**  
**SiteWatch™ Subscription**  
**STANDARD**

# GO BIG, WE'VE GOT YOU COVERED

CASE ProCare is the industry's most comprehensive and standard-from-the-factory heavy machine support program that's as powerful as the equipment it protects. Best of all, ProCare comes standard on all new G Series wheel loaders and keeps you covered for up to three years. It's the assurance businesses need to stay competitive, productive and profitable.







# SUPPORT COMES STANDARD



## **STRONGER PRODUCT SUPPORT SOLUTIONS**

Your CASE dealer knows how you can best maximize your equipment investment and uptime — with genuine CASE parts, expert service and a complete range of product support solutions including CASE remanufactured and all-makes parts. CASE supports better parts availability and faster deliveries through nine parts distribution centers in North America and a forecasting system to ensure that the right parts will be there when you need them. And only CASE dealers have exclusive access to the Electronic Service Tool (EST) that quickly pinpoints machine issues. Just ask your dealer for details.



## **FLEXIBLE FINANCIAL OPTIONS**

Specialized finance programs and flexible leasing packages are available for industry-leading CASE equipment while no-nonsense warranties and comprehensive protection plans ensure that your equipment is protected. As the only finance company dedicated to CASE, we offer strong products and services designed around your unique service needs.

\*See your dealer for the complete terms of CNH Industrial's Warranty and Limitations of Liability, which contains certain limits and exclusions. ProCare is a factory-fit program available on new heavy machine orders.



# ATTACHED TO VERSATILITY



## **INTEGRATED HYDRAULIC QUICK-COUPLER**

CASE offers an integrated hydraulic quick-coupler on our wheel loaders that lets operators conveniently switch out attachments from the comfort of the cab. Its factory-built design offers improved visibility and won't alter the physics or breakout force of the machine like after-market options will.

## **140 ATTACHMENTS AND THEN SOME**

G Series wheel loaders work with more than 140 CASE attachments, including buckets, forks, brooms and more. CASE also has partnerships with numerous attachment manufacturers for even greater versatility. Consult your dealer for details.

## **SMARTFIT™ BUCKET TEETH**

G Series buckets come standard with the innovative SmartFit bucket tooth system. These heavy-duty, self-sharpening teeth combine exceptional strength and unmatched ease of installation thanks to a hammerless fastener system with reusable locking pins. Available in a full range of styles.

# DIMENSIONS

## AND SPECIFICATIONS

SPECIFICATIONS	521G	621G	721G	821G	921G	1021G	1121G
<b>Engine</b>	FPT F4HFE413NB	FPT F4HFE613W	FPT F4HFE613T	FPT F4HFE613S	FPT F4HFE613R	FPT F2CFE614H	FPT F2CFE614F
<b>Emissions Certification</b>	Tier 4 Final	Tier 4 Final	Tier 4 Final	Tier 4 Final	Tier 4 Final	Tier 4 Final	Tier 4 Final
<b>Displacement – in<sup>3</sup> (L)</b>	275 (4.5)	411 (6.7)	411 (6.7)	411 (6.7)	411 (6.7)	531 (8.7)	531 (8.7)
<b>Cylinders</b>	4-cylinder in-line	6-cylinder in-line	6-cylinder in-line	6-cylinder in-line	6-cylinder in-line	6-cylinder in-line	6-cylinder in-line
<b>Net Horsepower – hp (kW)</b>	131 (98)	162 (121)	179 (133)	213 (159)	242 (180)	304 (227)	329 (245)
<b>Net Peak Torque – lb-ft (Nm)</b>	424 (575)	510 (692)	674 (914)	845 (1 145)	930 (1 261)	1,057 (1 433)	1,154 (1 564)
<b>Operating Weight – lb (kg)</b>	24,203 (10 978)	28,254 (12 816)	32,633 (14 802)	40,057 (18 170)	45,070 (20 443)	56,365 (25 567)	61,650 (27 964)
<b>Breakout Force – lb (kg)</b>	20,934 (9 495)	24,031 (10 900)	30,485 (13 828)	35,288 (16 007)	37,688 (17 095)	45,056 (20 437)	49,934 (22 650)
<b>Full Turn Tipping Load, ISO Deflected Tires – lb (kg)</b>	16,159 (7 330)	18,749 (8 504)	20,212 (9 168)	24,515 (11 120)	28,529 (12 940)	35,717 (16 201)	38,454 (17 443)
<b>Transmission Gears</b>	4F/3R	4 or 5F/3R	4 or 5F/3R	4 or 5F/3R	4 or 5F/3R	4F/3R	4F/3R
<b>Pin-on Bucket Size: GP with Bolt-on-Edge – yd<sup>3</sup> (m<sup>3</sup>)</b>	2.1 (1.6)	3.0 (2.3)	3.5 (2.7)	4.25 (3.2)	4.75 (3.6)	5.5 (4.2)	6.25 (4.8)
<b>Max. Material Density, ISO – lb/yd<sup>3</sup> (kg/m<sup>3</sup>)</b>	3,847 (2 283)	3,125 (1 854)	2,887 (1 713)	2,884 (1 711)	3,003 (1 782)	3,247 (1 927)	3,076 (1 825)
DIMENSIONS	521G	621G	721G	821G	921G	1021G	1121G
<b>Height to Top of ROPS Cab</b>	128.9 in (3 275 mm)	133.2 in (3 384 mm)	133.0 in (3 378 mm)	136.2 in (3 460 mm)	136.4 in (3 464 mm)	140.8 in (3 577 mm)	140.8 in (3 576 mm)
<b>Hinge Pin Height</b>	142.0 in (3 606 mm)	150.9 in (3 833 mm)	156.5 in (3 976 mm)	162.2 in (4 120 mm)	162.4 in (4 124 mm)	167.2 in (4 246 mm)	175.2 in (4 449 mm)
<b>Dump Height – Fully Raised, 45° Dump</b>	108.7 in (2 760 mm)	110.4 in (2 804 mm)	113.7 in (2 888 mm)	117.3 in (2 981 mm)	114.6 in (2 912 mm)	121.2 in (3 078 mm)	126.3 in (3 209 mm)
<b>Operating Height – Fully Raised with Spillguard</b>	181.6 in (4 613 mm)	198.6 in (5 044 mm)	208.4 in (5 294 mm)	215.4 in (5 471 mm)	220.1 in (5 589 mm)	229.3 in (5 824 mm)	242.0 in (6 147 mm)
<b>Bucket Reach – Fully Raised, 45° Dump</b>	37.9 in (962 mm)	39.8 in (1 010 mm)	46.0 in (1 169 mm)	43.4 in (1 102 mm)	46.8 in (1 189 mm)	49.8 in (1 265 mm)	50.1 in (1 273 mm)
<b>Wheelbase</b>	108.3 in (2 750 mm)	114.2 in (2 900 mm)	128.1 in (3 253 mm)	131.5 in (3 340 mm)	131.5 in (3 340 mm)	139.8 in (3 550 mm)	139.8 in (3 550 mm)
<b>Overall Length – Bucket Level on Ground</b>	260.3 in (6 612 mm)	290.6 in (7 380 mm)	304.0 in (7 721 mm)	315.1 in (8 004 mm)	322.7 in (8 198 mm)	352.3 in (8 948 mm)	361.1 in (9 172 mm)
<b>Ground Clearance</b>	13.4 in (341 mm)	15.3 in (389 mm)	15.1 in (384 mm)	17.0 in (431 mm)	17.1 in (435 mm)	17.2 in (437 mm)	17.2 in (437 mm)
<b>Overall Width without Bucket</b>	96.4 in (2 448 mm)	97.6 in (2 478 mm)	100.7 in (2 558 mm)	111.4 in (2 829 mm)	111.4 in (2 829 mm)	117.2 in (2 978 mm)	117.2 in (2 978 mm)
<b>Angle of Departure</b>	30°	25°	29°	29°	29°	23°	23°





# BUILDING A STRONG CASE.

Since 1842, we at CASE Construction Equipment have lived by an unwavering commitment to build practical, intuitive solutions that deliver both efficiency and productivity.

We continually strive to make it easier for our customers to implement emerging technologies and new compliance mandates.

Today, our global scale combined with our local expertise enables us to keep customers' real-world challenges at the center of our product development. This focus has led to numerous innovations like Ride Control™, electro-hydraulic controls, Blade Shake, PowerLift™, over-center boom design and the peace of mind that only CASE ProCare provides.

Every CASE machine is backed by more than 300 North American dealer locations, thousands of OEM, remanufactured and all-makes parts, and flexible financing and insurance options that provide the kind of reliable, steadfast support you expect from a professional partner.

We are passionate about improving the lives of others, whether investing in our veterans or raising awareness about local infrastructure initiatives through Dire States. Our goal is to build both stronger machines — and stronger communities.

At the end of the day, we do what's right by our customers and our communities so that they can count on CASE.

[CaseCE.com/GSeries](http://CaseCE.com/GSeries)

©2021 CNH Industrial America LLC. All rights reserved. CASE, CNH Industrial Capital and CNH Industrial Trademarks are registered in the United States and many other countries, owned by or licensed to CNH Industrial N.V., its subsidiaries or affiliates. Printed in U.S.A. Contains 10% post-consumer fiber.

**Form No. CCE202104WL**  
Replaces Form No. CCE201908GWL

IMPORTANT: CASE Construction Equipment Inc. reserves the right to change these specifications without notice and without incurring any obligation relating to such change. Availability of some models and equipment builds vary according to the country in which the equipment is used. The illustrations and text may include optional equipment and accessories and may not include all standard equipment. Your CASE dealer/distributor will be able to give you details of the products and their specifications available in your area.



CASE Construction Equipment is biodiesel-friendly.

NOTE: All engines meet current EPA emissions regulations. All specifications are stated in accordance with SAE Standards or Recommended Practices, where applicable.



Always read the Operator's Manual before operating equipment. Inspect equipment before using it, and be sure it is operating properly. Follow the product safety signs and use any safety features provided.



## ENGINE

Make	FPT
Model	F4HFE613R
Emissions Certification	Tier 4 Final
Emissions Technology	SCR/DOC
Type	4-stroke, turbocharged and air-to-air cooled
Cylinders	6-cylinder in-line
Bore/Stroke	4.09 x 5.20 in (104 x 132 mm)
Displacement	411 in <sup>3</sup> (6.7 L)
Fuel	#2 Diesel, #1 and #2 mixture permitted for cold temperatures
Fuel injection	Direct injection – electronic
Fuel filter	Replaceable, full flow spin-on cartridge
Fuel pump	Bosch CP 3.3
Gradeability:	
Side-to-side	35°
Fore and aft	35°
Air filter	Dry type elements w/ warning restriction indicator
Mid-mount cooling module w/ auto reversing fan:	Mid-mount air/water w/ Lube Oil Cooler
Fan – hydraulic driven:	
Style	8 blade puller
Diameter	32 in (813 mm)
Water pump	Integral
Engine oil pump operating angle ratings:	
Side-to-side	35°
Fore and aft	35°
Oil filtration	Replaceable, full flow spin-on cartridge
Engine speeds	RPM
Rated – full load	2000
Horsepower – Maximum Power:	
Peak gross @ 1600 RPM	255 hp (190 kW)
Net rated @ 2000 RPM	224 hp (167 kW)
Peak net @ 1600 RPM	242 hp (180 kW)
Torque – Maximum Power:	
Gross @ 1300 RPM	959 lb-ft (1 300 N-m)
Net @ 1300 RPM	930 lb-ft (1 261 N-m)
Net torque rise:	
Maximum power range	58%

NOTE: Gross horsepower and torque per SAE J1995. Net horsepower and torque per SAE J1349.

## DRIVETRAIN

Transmission:	4F/3R Proportional w/ Electronic Control Module torque sensing autoshift/manual shift and modulation	
Gears	Helical cut	
Gear ratios – 4-speed	Forward/Reverse	
1st	4.152/3.937	
2nd	2.184/2.071	
3rd	1.072/1.017	
4th	0.636/ –	
Gear ratios – 5-speed	Forward/Reverse	
1st	3.921/3.718	
2nd	2.255/2.138	
3rd	1.466/0.894	
4th	0.942/ –	
5th	0.613/ –	
Torque converter:		
Stall ratio – 4-speed	2.283:1	
Stall ratio – 5-speed	2.350:1	
Differential:		
Front axle equipped w/ locking differential		
Rear axle equipped w/ open differential		
Rear axle oscillation	24° total	
Front and rear axles:		
Differential ratio	4.11	
Planetary ratio	6.00	
Final axle ratio	24.67	
Planetaries	Outboard	
Service brakes:		
Hydraulically actuated, maintenance-free, multiple wet disc w/ accumulator to all four wheels		
Brake surface area:		
Front hub	841 in <sup>2</sup> (0.542 m <sup>2</sup> )	
Rear hub	721 in <sup>2</sup> (0.465 m <sup>2</sup> )	
Parking brakes:		
Spring-applied hydraulic release disc on transmission output shaft neutralizes power flow to wheels when engaged		
Travel speeds – 4-speed transmission:	Forward	Reverse
	mph (kph)	mph (kph)
1st	4.0 (6.4)	4.2 (6.8)
2nd	7.4 (12.0)	7.8 (12.6)
3rd	14.3 (23.1)	15.0 (24.2)
4th	22.4 (36.0)	–
Travel speeds – 5-speed transmission:	Forward	Reverse
	mph (kph)	mph (kph)
1st	4.0 (6.4)	4.2 (6.8)
2nd	6.9 (11.1)	7.3 (11.7)
3rd	10.6 (17.0)	17.2 (27.7)
4th	16.3 (26.3)	–
5th	25.0 (40.0)	–

NOTE: Travel speeds at full engine throttle w/ 23.5-R25 L3 Radial Tires.

## ELECTRICAL

Voltage	24 Volts, negative ground
Alternator	120 amp
Batteries (2)	12-volt

## OPERATOR ENVIRONMENT

ROPS cab AC w/ heat; 8" LCD touchscreen display, adjustable armrest w/ 3 configurable buttons; Key start; Articulated power steering w/ tilt column; Fully adjustable, heated air-ride seat w/ headrest; AM/FM Bluetooth radio w/ auxiliary input; Cab convenience package: rear sun shade, interior mirror, under the seat drawer, 12V accessory port, & coat hook; Foot throttle; Single lever (joystick) loader control w/ fully adjustable wrist rest, 2 cup holders; 2 interior rear view mirrors; 3 inch (76 mm) retractable seat belt; Integrated 4-corner strobe; Multiple storage trays; Single brake pedal; F/N/R shuttle switch; Left and Right external rear view mirrors; Sound suppression kit; Pressurized air filtering; Anti-glare window strip; Front and Rear Defroster; Side window, partial/fully open; 2 Dome lights; Wipers, rear and intermittent front; Windshield washers, front and rear; Rubber floor mat; Horn.

### Displays/Gauges:

Digital:  
Transmission oil temperature; Engine coolant temperature; Fuel level; DEF level.

LCD screen:  
Hour meter; Engine speed; Travel speed; Time; Automatic transmission indication; Current gear selection; FNR indication; DeClutch indication; Engine mode indication; Trip computer A/B; Fuel consumption; Multiple languages, Metric/English; Engine diagnostics; Transmission diagnostics; Warning prompts; Error reporting; Diff. Lock\*.

### Audible/Visual alarms:

Warning lights:  
Four-way flashers and turn signals; Brake pressure; Lamp/high beam indication; Engine Block Heater.

### Caution warnings:

Parking brake; Coolant temperature; Hydraulic oil temperature; Transmission oil temperature; Air filter; Transmission filter; Hydraulic filter; Alternator; Low fuel.

### Critical warnings:

Engine oil pressure; Brake pressure; Steering pressure – w/ aux steering\*; Coolant temperature; Hydraulic oil temperature; Transmission oil temperature.

### Backup alarm

### Maintenance reminders:

Cab air filter; Engine oil filter; Fuel pre-filter; DEF tank vent filter; SCR supply filter; Hydraulic oil and filter; Engine air filter; Engine coolant; Drive belt; Cab recirculation filter; Engine breather filter; Transmission breather; Front and rear axle fluid; SCR supply module filter.

NOTE: \*If equipped w/ option.

## OPERATING WEIGHT

Z-Bar  
Unit equipped w/ 23.5-R25 L3 Radial tires;  
ROPS cab w/ heater and AC; Heavy-duty  
counterweight – 6,435 lb (2 919 kg); Heavy-duty  
batteries; Front and rear fenders; Lights; Full  
fuel; Full urea; 165 lb (75 kg) operator; 4.75 yd<sup>3</sup>  
(3.6 m<sup>3</sup>) GP pin on w/ bolt on edge:  
45,070 lb (20 443 kg)

XR  
Unit equipped w/ 23.5-R25 L3 Radial tires;  
ROPS cab w/ heater and AC; Heavy-duty  
counterweight – 6,435 lb (2 919 kg); Heavy-duty  
batteries; Front and rear fenders; Lights; Full  
fuel; Full urea; 165 lb (75 kg) operator; 4.75 yd<sup>3</sup>  
(3.6 m<sup>3</sup>) GP pin on w/ bolt on edge:  
45,651 lb (20 707 kg)

## HYDRAULICS

Main pump – steering/implement:  
Closed center pressure/flow compensated

---

Tandem variable displacement – load-sensing:  
Max. rated flow P1: 42.6 gpm @ 2000 RPM  
(162 L/min @ 2000 RPM)  
Max. rated flow P2: 31.6 gpm @ 2000 RPM  
(120 L/min @ 2000 RPM)

---

Loader control valve:  
Closed-center, sectional 2, 3 or 4-function  
w/ control for lift, tilt and auxiliary hydraulics

---

Loader auxiliary steering:  
Hydraulic orbital center-pivot articulating  
w/ on-demand oil flow

---

High pressure standby:  
Implement 3,625 psi (25 000 kPa)  
Steering 3,500 psi (24 132 kPa)

---

Filtration:  
Filtered vent w/ relief on hydraulic reservoir,  
maintains 3-5 psi on reservoir, 10-micron, return  
filter furnishes only clean oil to all components  
of the system

## SERVICE CAPACITIES

Fuel tank	76 gal (288.0 L)
-----------	------------------

---

DEF tank – Diesel Exhaust Fluid:	
Usable	9.8 gal (37.1 L)
Total	15.6 gal (58.9 L)

---

Hydraulic system:	
Reservoir	29.0 gal (110.0 L)
Total	53.0 gal (200.0 L)

---

Transmission:	
Service w/ filter	36.0 qt (34.1 L)

---

Front and rear axle:	
Front axle	44.4 qt (42.0 L)
Rear axle	42.3 qt (40.0 L)

---

Engine oil w/ filter	16.0 qt (15.1 L)
----------------------	------------------

---

Cooling system	32 qt (30.0 L)
----------------	----------------

## OTHER SPECIFICATIONS

Lift cylinder:	
Bore diameter	6.0 in (152.4 mm)
Rod diameter	3.5 in (88.9 mm)
Stroke	33.3 in (845.7 mm)

---

Dump cylinder:	
Bore diameter	7.0 in (177.8 mm)
Rod diameter	4.0 in (101.6 mm)
Stroke	23.6 in (600 mm)

---

Loader:  
Z-Bar loader linkage; Single control for  
lift and tilt; Positive hold float; Automatic  
return-to-dig; Automatic height control;  
Automatic return-to-travel; Brake pedal  
transmission disconnect; Bucket position  
indicator on bucket.

---

Cycle time:	
Raise w/ rated bucket load	6.3 sec
Dump w/ rated bucket load	1.5 sec
Float down	3.6 sec

---

Sound level in Cab (LpA)	69 dB(A)
--------------------------	----------

---

Exterior sound level (LwA)	104 dB(A)
----------------------------	-----------

NOTE: Sound level data tested in accordance  
with ISO6395, 6396, 3744.

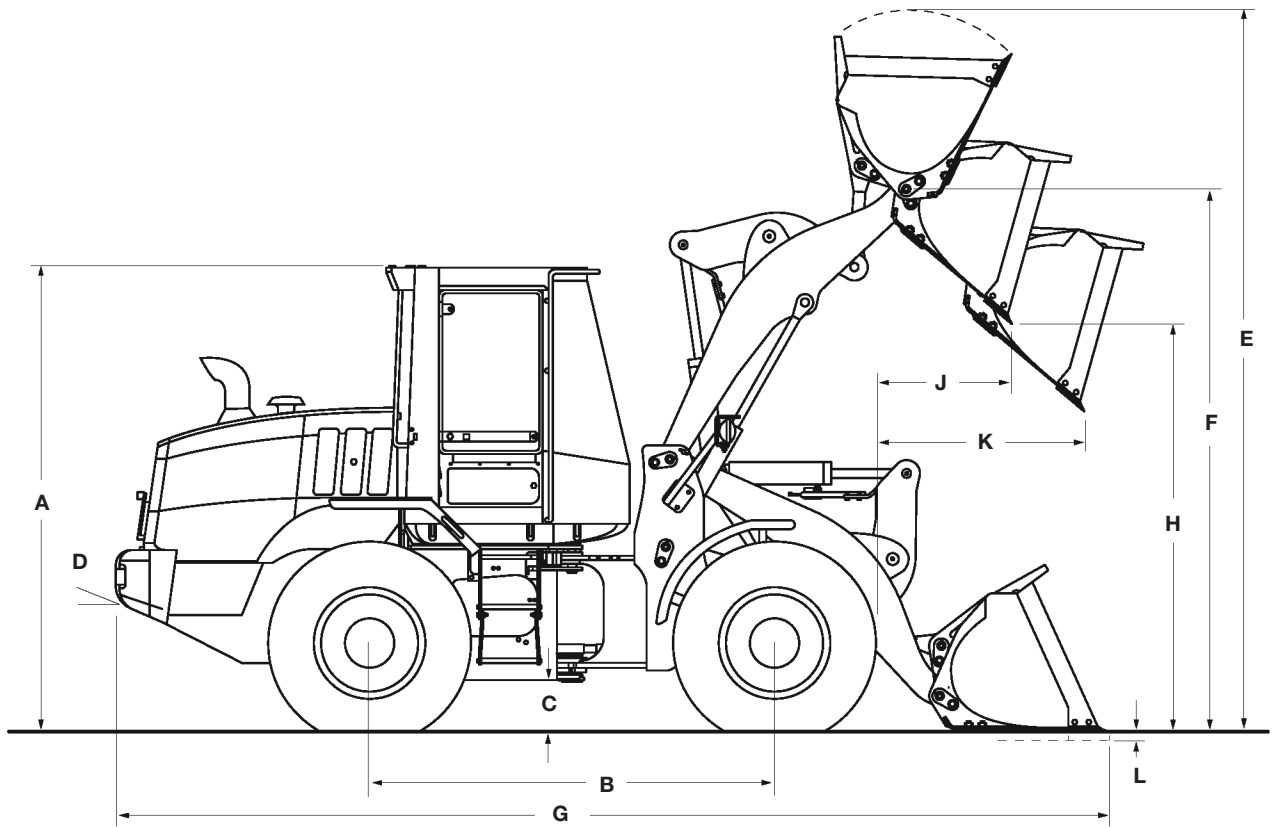

Line drawings are for illustrative purpose only and may not be exact representation of unit.

### DIMENSIONS

A. Height to top of ROPS cab	136.4 in (3 464 mm)
Height to drawbar	42.7 in (1 085 mm)
B. Wheelbase	131.5 in (3 340 mm)
C. Ground clearance	17.1 in (435 mm)
D. Angle of departure	29°
Width:	
Overall* without bucket	111.4 in (2 829 mm)
Tread width	87.8 in (2 230 mm)
Turning radius* – outside	236.3 in (6 003 mm)
Turning angle:	
From center	40°
Total angle	80°
Rear axle oscillation – total	24°

NOTE: \*Dimensions taken with 23.5-R25 L3 Radial Tires. Additional dimensions on pages 4 through 6.

### WEIGHT ADJUSTMENTS

Select Options	Weight Adjustment	Tipping Load Adjustment Straight: Deflected*	Tipping Load Adjustment 40° Turn: Deflected*
23.5-R25 L2 Radial tires	-28 lb (-13 kg)	-102 lb (-46 kg)	-117 lb (-53 kg)
23.5-R25 L3 Bias tires	-504 lb (-229 kg)	-459 lb (-208 kg)	-1,048 lb (-475 kg)

NOTE: Unit equipped with Z-Bar loader arms, 4.75 yd<sup>3</sup> (3.6 m<sup>3</sup>) pin on bucket with bolt-on edge, 23.5-R25 L3 Radial Tires, ROPS cab with heater and air conditioner, heavy counterweight, heavy-duty batteries, front and rear fenders, full fuel and 165 lb (75 kg) operator. Adjust select options from rated weight.

\*Tipping loads: ISO 14397-1 Deflected Tires.

**PERFORMANCE SPECS**

<b>921G Z-Bar*</b>		<b>4.75 yd<sup>3</sup> (3.6 m<sup>3</sup>) Bucket with Bolt-on Edge - Pin On</b>	<b>4.6 yd<sup>3</sup> (3.5 m<sup>3</sup>) Bucket with Teeth - Pin On</b>
Operating weight		45,070 lb (20 443 kg)	44,929 lb (20 379 kg)
<b>E.</b> Operating height – fully raised with spillguard		220.1 in (5 589 mm)	220.1 in (5 589 mm)
<b>F.</b> Hinge pin height – fully raised		162.4 in (4 124 mm)	162.4 in (4 124 mm)
<b>G.</b> Overall length – bucket level on ground		322.7 in (8 198 mm)	328.6 in (8 347 mm)
Dump angle – fully raised		55°	55°
<b>H.</b> Dump height – fully raised, 45° dump		114.6 in (2 912 mm)	110.9 in (2 816 mm)
<b>J.</b> Bucket reach – fully raised, 45° dump		46.8 in (1 189 mm)	51.2 in (1 302 mm)
<b>K.</b> Bucket reach – 7 ft 0 in (2.13 m) height, 45° dump		68.9 in (1 750 mm)	71.4 in (1 813 mm)
<b>L.</b> Dig depth		2.9 in (74 mm)	2.9 in (75 mm)
Operating load – ISO Rigid Tires		15,544 lb (7 051 kg)	15,775 lb (7 156 kg)
Operating load – ISO Deflected Tires		14,264 lb (6 470 kg)	14,479 lb (6 567 kg)
Maximum material density – ISO Rigid Tires		3,272 lb/yd <sup>3</sup> (1 942 kg/m <sup>3</sup> )	3,429 lb/yd <sup>3</sup> (2 035 kg/m <sup>3</sup> )
Maximum material density – ISO Deflected Tires		3,003 lb/yd <sup>3</sup> (1 782 kg/m <sup>3</sup> )	3,148 lb/yd <sup>3</sup> (1 868 kg/m <sup>3</sup> )
Tipping load – ISO Rigid Tires:	Straight	37,921 lb (17 201 kg)	38,448 lb (17 440 kg)
	40° turn	31,088 lb (14 101 kg)	31,551 lb (14 311 kg)
Tipping load – ISO Deflected Tires:	Straight	35,693 lb (16 190 kg)	36,187 lb (16 414 kg)
	40° turn	28,529 lb (12 940 kg)	28,958 lb (13 135 kg)
Lift capacity:	Full height	26,722 lb (12 120 kg)	26,882 lb (12 193 kg)
	Ground	45,618 lb (20 692 kg)	47,935 lb (21 743 kg)
Breakout force with tilt cylinder		37,688 lb (17 095 kg)	40,265 lb (18 264 kg)
Loader clearance circle with bucket		525.8 in (13 356 mm)	529.1 in (13 440 mm)

<b>921G XR</b>		<b>4.75 yd<sup>3</sup> (3.6 m<sup>3</sup>) Bucket with Bolt-on Edge - Pin On</b>	<b>4.6 yd<sup>3</sup> (3.5 m<sup>3</sup>) Bucket with Teeth - Pin On</b>
Operating weight		45,651 lb (20 707 kg)	45,510 lb (20 643 kg)
<b>E.</b> Operating height – fully raised with spillguard		237.4 in (6 031 mm)	237.4 in (6 031 mm)
<b>F.</b> Hinge pin height – fully raised		179.7 in (4 565 mm)	179.7 in (4 565 mm)
<b>G.</b> Overall length – bucket level on ground		341.9 in (8 684 mm)	347.7 in (8 833 mm)
Dump angle – fully raised		49°	49°
<b>H.</b> Dump height – fully raised, 45° dump		132.0 in (3 353 mm)	128.2 in (3 257 mm)
<b>J.</b> Bucket reach – fully raised, 45° dump		51.2 in (1 302 mm)	55.7 in (1 414 mm)
<b>K.</b> Bucket reach – 7 ft 0 in (2.13 m) height, 45° dump		86.3 in (2 191 mm)	89.0 in (2 262 mm)
<b>L.</b> Dig depth		5.5 in (141 mm)	5.6 in (141 mm)
Operating load – ISO Rigid Tires		13,119 lb (5 951 kg)	13,310 lb (6 037 kg)
Operating load – ISO Deflected Tires		11,521 lb (5 226 kg)	11,693 lb (5 304 kg)
Maximum material density – ISO Rigid Tires		2,762 lb/yd <sup>3</sup> (1 639 kg/m <sup>3</sup> )	2,894 lb/yd <sup>3</sup> (1 717 kg/m <sup>3</sup> )
Maximum material density – ISO Deflected Tires		2,426 lb/yd <sup>3</sup> (1 439 kg/m <sup>3</sup> )	2,542 lb/yd <sup>3</sup> (1 508 kg/m <sup>3</sup> )
Tipping load – ISO Rigid Tires:	Straight	30,674 lb (13 914 kg)	31,090 lb (14 102 kg)
	40° turn	26,238 lb (11 901 kg)	26,621 lb (12 075 kg)
Tipping load – ISO Deflected Tires:	Straight	28,901 lb (13 109 kg)	29,293 lb (13 287 kg)
	40° turn	23,042 lb (10 452 kg)	23,387 lb (10 608 kg)
Lift capacity:	Full height	24,608 lb (11 162 kg)	24,767 lb (11 234 kg)
	Ground	36,861 lb (16 720 kg)	37,203 lb (16 875 kg)
Breakout force with tilt cylinder		38,323 lb (17 383 kg)	40,940 lb (18 570 kg)
Loader clearance circle with bucket		545.6 in (13 858 mm)	549.6 in (13 959 mm)

<b>921G</b>		<b>Z-Bar/XR</b>	<b>Z-Bar/XR</b>
Maximum rollback:	Ground	41°/37°	41°/37°
	Carry position	45°/43°	45°/43°
	@ Full height	59°/60°	59°/60°
Maximum grading angle with bucket – back dragging		61°/63°	62°/65°
SAE bucket capacity – struck		4.08 yd <sup>3</sup> (3.12 m <sup>3</sup> )	3.98 yd <sup>3</sup> (3.04 m <sup>3</sup> )
	Heaped	4.75 yd <sup>3</sup> (3.63 m <sup>3</sup> )	4.60 yd <sup>3</sup> (3.52 m <sup>3</sup> )
Bucket width – outside		119.3 in (3 030 mm)	119.2 in (3 027 mm)
Bucket weight		3,674 lb (1 666 kg)	3,532 lb (1 602 kg)



**PERFORMANCE SPECS**

<b>921G Z-Bar*</b>		<b>4.0 yd<sup>3</sup> (3.1 m<sup>3</sup>) Bucket with Bolt-on Edge - JRB Coupler</b>	<b>3.8 yd<sup>3</sup> (2.9 m<sup>3</sup>) Bucket with Teeth - JRB Coupler</b>	<b>4.0 yd<sup>3</sup> (3.1 m<sup>3</sup>) Bucket with Bolt-on Edge - ACS Coupler</b>	<b>3.8 yd<sup>3</sup> (2.9 m<sup>3</sup>) Bucket with Teeth - ACS Coupler</b>
Operating weight		46,166 lb (20 941 kg)	46,025 lb (20 877 kg)	46,220 lb (20 965 kg)	46,078 lb (20 901 kg)
<b>E.</b> Operating height – fully raised with spillguard		222.1 in (5 641 mm)	222.1 in (5 641 mm)	219.0 in (5 562 mm)	219.0 in (5 563 mm)
<b>F.</b> Hinge pin height – fully raised		162.3 in (4 123 mm)	162.3 in (4 123 mm)	162.3 in (4 122 mm)	162.3 in (4 123 mm)
<b>G.</b> Overall length – bucket level on ground		328.2 in (8 337 mm)	334.1 in (8 486 mm)	324.0 in (8 230 mm)	329.9 in (8 379 mm)
Dump angle – fully raised		55°	55°	55°	55°
<b>H.</b> Dump height – fully raised, 45° dump		111.1 in (2 821 mm)	107.3 in (2 725 mm)	113.8 in (2 890 mm)	110.0 in (2 794 mm)
<b>J.</b> Bucket reach – fully raised, 45° dump		51.0 in (1 295 mm)	55.4 in (1 408 mm)	47.8 in (1 213 mm)	52.2 in (1 326 mm)
<b>K.</b> Bucket reach – 7 ft 0 in (2.13 m) height, 45° dump		71.3 in (1 810 mm)	73.6 in (1 869 mm)	69.4 in (1 764 mm)	71.9 in (1 826 mm)
<b>L.</b> Dig depth		2.9 in (75 mm)	3.0 in (76 mm)	2.9 in (75 mm)	3.0 in (76 mm)
Operating load – ISO Rigid Tires		14,056 lb (6 376 kg)	14,268 lb (6 472 kg)	14,458 lb (6 558 kg)	14,679 lb (6 658 kg)
Operating load – ISO Deflected Tires		12,882 lb (5 843 kg)	13,079 lb (5 933 kg)	13,249 lb (6 010 kg)	13,454 lb (6 103 kg)
Maximum material density – ISO Rigid Tires		3,514 lb/yd <sup>3</sup> (2 085 kg/m <sup>3</sup> )	3,755 lb/yd <sup>3</sup> (2 228 kg/m <sup>3</sup> )	3,615 lb/yd <sup>3</sup> (2 145 kg/m <sup>3</sup> )	3,863 lb/yd <sup>3</sup> (2 292 kg/m <sup>3</sup> )
Maximum material density – ISO Deflected Tires		3,220 lb/yd <sup>3</sup> (1 911 kg/m <sup>3</sup> )	3,442 lb/yd <sup>3</sup> (2 042 kg/m <sup>3</sup> )	3,312 lb/yd <sup>3</sup> (1 965 kg/m <sup>3</sup> )	3,541 lb/yd <sup>3</sup> (2 101 kg/m <sup>3</sup> )
Tipping load – ISO Rigid Tires:	Straight	34,496 lb (15 647 kg)	34,979 lb (15 866 kg)	35,472 lb (16 090 kg)	35,976 lb (16 318 kg)
	40° turn	28,112 lb (12 751 kg)	28,537 lb (12 944 kg)	28,916 lb (13 116 kg)	29,358 lb (13 317 kg)
Tipping load – ISO Deflected Tires:	Straight	32,471 lb (14 728 kg)	32,926 lb (14 935 kg)	33,380 lb (15 141 kg)	33,854 lb (15 356 kg)
	40° turn	25,763 lb (11 686 kg)	26,158 lb (11 865 kg)	26,498 lb (12 019 kg)	26,908 lb (12 205 kg)
Lift capacity:	Full height	25,513 lb (11 573 kg)	25,673 lb (11 645 kg)	25,510 lb (11 571 kg)	25,864 lb (11 732 kg)
	Ground	33,475 lb (15 184 kg)	34,900 lb (15 830 kg)	38,169 lb (17 313 kg)	48,195 lb (21 861 kg)
Breakout force with tilt cylinder		33,854 lb (15 356 kg)	35,974 lb (16 317 kg)	36,514 lb (16 562 kg)	38,959 lb (17 671 kg)
Loader clearance circle with bucket		529.0 in (13 437 mm)	532.4 in (13 523 mm)	526.5 in (13 374 mm)	529.9 in (13 459 mm)

<b>921G XR</b>		<b>4.0 yd<sup>3</sup> (3.1 m<sup>3</sup>) Bucket with Bolt-on Edge - JRB Coupler</b>	<b>3.8 yd<sup>3</sup> (2.9 m<sup>3</sup>) Bucket with Teeth - JRB Coupler</b>	<b>4.0 yd<sup>3</sup> (3.1 m<sup>3</sup>) Bucket with Bolt-on Edge - ACS Coupler</b>	<b>3.8 yd<sup>3</sup> (2.9 m<sup>3</sup>) Bucket with Teeth - ACS Coupler</b>
Operating weight		46,748 lb (21 204 kg)	46,606 lb (21 140 kg)	46,801 lb (21 228 kg)	46,659 lb (21 164 kg)
<b>E.</b> Operating height – fully raised with spillguard		239.5 in (6 082 mm)	239.5 in (6 082 mm)	236.4 in (6 004 mm)	236.4 in (6 004 mm)
<b>F.</b> Hinge pin height – fully raised		179.7 in (4 564 mm)	179.7 in (4 564 mm)	179.7 in (4 564 mm)	179.7 in (4 564 mm)
<b>G.</b> Overall length – bucket level on ground		347.4 in (8 823 mm)	353.2 in (8 972 mm)	343.2 in (8 716 mm)	349.0 in (8 865 mm)
Dump angle – fully raised		49°	49°	49°	49°
<b>H.</b> Dump height – fully raised, 45° dump		128.4 in (3 263 mm)	124.7 in (3 167 mm)	131.2 in (3 331 mm)	127.4 in (3 235 mm)
<b>J.</b> Bucket reach – fully raised, 45° dump		55.4 in (1 408 mm)	59.9 in (1 521 mm)	52.2 in (1 326 mm)	56.6 in (1 439 mm)
<b>K.</b> Bucket reach – 7 ft 0 in (2.13 m) height, 45° dump		88.9 in (2 258 mm)	91.5 in (2 325 mm)	86.9 in (2 206 mm)	89.6 in (2 276 mm)
<b>L.</b> Dig depth		5.6 in (141 mm)	5.6 in (142 mm)	5.6 in (141 mm)	5.6 in (142 mm)
Operating load – ISO Rigid Tires		11,886 lb (5 392 kg)	12,064 lb (5 472 kg)	12,177 lb (5 523 kg)	11,685 lb (5 300 kg)
Operating load – ISO Deflected Tires		10,395 lb (4 715 kg)	10,557 lb (4 788 kg)	10,650 lb (4 831 kg)	10,816 lb (4 906 kg)
Maximum material density – ISO Rigid Tires		2,972 lb/yd <sup>3</sup> (1 763 kg/m <sup>3</sup> )	3,175 lb/yd <sup>3</sup> (1 884 kg/m <sup>3</sup> )	3,044 lb/yd <sup>3</sup> (1 806 kg/m <sup>3</sup> )	3,075 lb/yd <sup>3</sup> (1 825 kg/m <sup>3</sup> )
Maximum material density – ISO Deflected Tires		2,599 lb/yd <sup>3</sup> (1 542 kg/m <sup>3</sup> )	2,778 lb/yd <sup>3</sup> (1 648 kg/m <sup>3</sup> )	2,662 lb/yd <sup>3</sup> (1 580 kg/m <sup>3</sup> )	2,846 lb/yd <sup>3</sup> (1 689 kg/m <sup>3</sup> )
Tipping load – ISO Rigid Tires:	Straight	27,963 lb (12 684 kg)	28,350 lb (12 860 kg)	28,646 lb (12 993 kg)	28,778 lb (13 053 kg)
	40° turn	23,773 lb (10 783 kg)	24,128 lb (10 944 kg)	24,353 lb (11 046 kg)	23,371 lb (10 601 kg)
Tipping load – ISO Deflected Tires:	Straight	26,322 lb (11 940 kg)	26,689 lb (12 106 kg)	26,960 lb (12 229 kg)	27,338 lb (12 400 kg)
	40° turn	20,790 lb (9 430 kg)	21,113 lb (9 577 kg)	21,299 lb (9 661 kg)	21,631 lb (9 812 kg)
Lift capacity:	Full height	23,413 lb (10 620 kg)	23,572 lb (10 692 kg)	23,404 lb (10 616 kg)	23,741 lb (10 769 kg)
	Ground	34,420 lb (15 613 kg)	34,752 lb (15 763 kg)	35,045 lb (15 896 kg)	36,562 lb (16 584 kg)
Breakout force with tilt cylinder		34,432 lb (15 618 kg)	36,585 lb (16 595 kg)	37,135 lb (16 844 kg)	39,618 lb (17 970 kg)
Loader clearance circle with bucket		549.4 in (13 955 mm)	553.5 in (14 059 mm)	546.4 in (13 880 mm)	550.5 in (13 982 mm)

<b>921G</b>		<b>Z-Bar/XR</b>	<b>Z-Bar/XR</b>	<b>Z-Bar/XR</b>	<b>Z-Bar/XR</b>
Maximum rollback:	Ground	41°/37°	41°/37°	41°/37°	41°/37°
	Carry position	45°/43°	45°/43°	45°/43°	45°/43°
	@ Full height	59°/60°	59°/60°	59°/60°	59°/60°
Maximum grading angle with bucket – back dragging		62°/65°	64°/67°	61°/64°	63°/65°
SAE bucket capacity – struck		3.41 yd <sup>3</sup> (2.61 m <sup>3</sup> )	3.25 yd <sup>3</sup> (2.48 m <sup>3</sup> )	3.41 yd <sup>3</sup> (2.61 m <sup>3</sup> )	3.25 yd <sup>3</sup> (2.48 m <sup>3</sup> )
	Heaped	4.00 yd <sup>3</sup> (3.06 m <sup>3</sup> )	3.80 yd <sup>3</sup> (2.91 m <sup>3</sup> )	4.00 yd <sup>3</sup> (3.06 m <sup>3</sup> )	3.80 yd <sup>3</sup> (2.91 m <sup>3</sup> )
Bucket width – outside		119.3 in (3 030 mm)	119.2 in (3 027 mm)	119.3 in (3 030 mm)	119.2 in (3 027 mm)
Bucket weight		4,770 lb (2 164 kg)	4,629 lb (2 100 kg)	4,824 lb (2 188 kg)	4,682 lb (2 124 kg)

NOTE: \*Z-Bar performance data shown with full counterweight.

Performance data unit equipped with 23.5-R25 L3 Radial tires, ROPS cab with heater and air conditioner, full counterweight, standard batteries, front and rear fenders, full fuel and 165 lb (75 kg) operator. Specifications per SAE J732, J1234, J695, J742, and J818.

## STANDARD EQUIPMENT

### OPERATOR ENVIRONMENT

See page 1

### ENGINE

CASE/FPT F4HFE613R  
Tier 4 Final Certified  
Selective Catalytic Reduction (SCR) with Diesel Oxidation Catalyst  
Selectable work modes:  
Maximum Mode  
Smart Mode  
Turbocharger  
Charge air cooling  
Automatic belt tensioner  
Integral engine oil cooling  
Fuel filter with water trap  
Dual-element dry-type air cleaner  
Hydraulic-driven cooling fan  
Air-cooled radiator  
Mid-mounted cooling module with hydraulically driven auto-reversing fan  
Engine block heater  
Sound suppression kit  
Ejector type air precleaner  
Common rail electronic fuel injection

### LOADER

See page 2 – Operating weight,  
Other specifications

### DRIVETRAIN

4-wheel drive  
4F/3R Selectable autoshift/manual shift transmission  
Electronic Control Module – programmable, computer controlled proportional shifting with programmable gear selection  
Onboard diagnostics  
Single lever electronic shift control  
F/N/R switch in loader control handle  
Downshift button  
Torque converter  
Heavy-duty axles:  
With locking front differential and open/conventional rear differential  
Outboard planetary axles  
Transmission oil cooler  
Brake pedal transmission disconnect – declutch  
Hydraulic wet disc brakes  
Spring-applied hydraulic release parking brake  
Limp-Home Mode  
Greaseable rear axle trunnion  
3-piece rims

### HYDRAULICS

Adjustable Electro-hydraulic – EH joystick loader control and 3 configurable buttons  
Adjustable EH settings:  
Smooth  
Moderate  
Aggressive  
Integrated Payload System  
Auxiliary Hydraulics  
Ride Control™  
Locking hydraulics for coupler  
EH Parallel Lift  
Low-effort steering  
Hydraulic driven cooling fan  
Diagnostic quick couplers  
Split flange hydraulic connections – 1 in or greater  
Hydraulic oil cooler

### ELECTRICAL

Alternator and voltage regulator  
Battery isolator/electrical disconnect  
120 amp alternator  
(2) 700 CCA 12-volt batteries  
Electric starter  
Lights:  
Integrated 4-corner strobe  
2 Front and 2 rear halogen flood lights  
2 Front driving headlights – high/low beam with integrated turn signals  
2 LED stop/tail lights with integrated turn signals  
Key start/stop switch  
Backup alarm  
Centrally located fuse box with all electrical circuits protected  
Remote jump start posts

### OTHER

Electric hood lift  
Front and rear fenders, partial coverage  
External rear view mirrors  
Heavy counterweight  
Drawbar hitch  
Articulation locking bar  
Lift arm locking bar  
Lift and tie-down points – front/rear  
Rear frame side covers  
License plate brackets; front bracket and lit rear bracket  
Rubber steering stops  
Standard fenders with Left hand and Right hand steps  
Grouped remote-mounted ecology drains:  
Engine oil  
Engine coolant  
Hydraulic oil

### TELEMATICS

CASE SiteWatch™ Telematics – includes hardware and a 3-yr Advanced data subscription  
SiteConnect Module provides remote diagnostics capability

## OPTIONAL EQUIPMENT

### OPERATOR ENVIRONMENT

Leather trimmed heated air seat with active suspension  
In cab powered cooler box  
In cab accessory mount  
Rear view camera  
External heated rear view mirrors  
Front LED driving/headlights  
LED front and rear work lights – 4 front, 2 rear

### DRIVETRAIN

5F/3R Autoshift/manual shift transmission, lockup torque converter, PowerInch de-clutch  
Cold weather package:  
Heavy-duty (2) 950 CCA 12V batteries  
Fuel heater  
Hydraulic oil cooler bypass  
Low temperature hydraulic oil  
Fast-warm hydraulic valve

### HYDRAULICS

Secondary steering  
Tire Pressure Monitoring System  
2-function EH loader control with one auxiliary function  
4-function EH loader control with two proportional auxiliary controls  
2 Single axis EH levers and one auxiliary function  
Joystick steering with or without secondary steering

### LOADER

XR extended reach version  
Attachment auxiliary hydraulics  
Coupler systems – JRB or ACS compatible  
Buckets – see pages 4 through 5

### TIRES

23.5 x 25 L2 bias – dirt/traction  
23.5 x 25 L3 bias – rock  
23.5-R25 L2 radial – dirt/traction  
23.5-R25 L3 radial – rock  
23.5-R25 radial Michelin SnoPlus  
Axle oscillation stops

### OTHER

12.4 mph (20 kph) maximum speed control  
Special paint  
Skid plate and transmission  
Wide full coverage fenders with right and left hand steps

**CaseCE.com**

©2022 CNH Industrial America LLC. All rights reserved. CASE is a trademark registered in the United States and many other countries, owned by or licensed to CNH Industrial N.V., its subsidiaries or affiliates. CNH Industrial Capital is a trademark in the United States and many other countries, owned by or licensed to CNH Industrial N.V., its subsidiaries or affiliates. Printed in U.S.A. Contains 10% post-consumer fiber.

IMPORTANT: CASE Construction Equipment Inc. reserves the right to change these specifications without notice and without incurring any obligation relating to such change. Availability of some models and equipment builds vary according to the country in which the equipment is used. The illustrations and text may include optional equipment and accessories and may not include all standard equipment. Your CASE dealer/distributor will be able to give you details of the products and their specifications available in your area.



CASE Construction Equipment is biodiesel-friendly. NOTE: All engines meet current EPA emissions regulations. All specifications are stated in accordance with SAE Standards or Recommended Practices, where applicable.



Always read the Operator's Manual before operating any equipment. Inspect equipment before using it, and be sure it is operating properly. Follow the product safety signs and use any safety features provided.

Form No. CCE202212921G  
Replaces Form No. CCE202104921G

**921G**

**7 of 7**



WARRANTY AND LIMITATION OF LIABILITY AGREEMENT HEAVY - CASE CONSTRUCTION EQUIPMENT

The Case Warranty

The Case Warranty is a limited warranty that is provided to the initial retail purchaser in return for consideration paid as part of the purchase price of the product. The selling dealer must review the warranty coverage with the initial retail purchaser and obtain signature on this document.

New Limited Warranty

The warranty described here is from CNH Industrial America LLC and in Canada, CNH Industrial Canada Ltd., both of which are referred to in this agreement as "Case". This warranty is for Case products sold and registered in the United States or Canada and normally operated in the United States or Canada. This warranty does NOT apply to any product normally operated outside of the United States and/or Canada, or to any unit purchased outside of the United States or Canada and imported in for any reason other than a customer relocation/personal move.

Warranty Period

For the products listed below, the Warranty Period for all coverage begins at the time that any person, dealer or agent first places the unit into service. At the latest, a unit is considered to be placed into service when purchased or delivered to an initial retail purchaser. Certain demonstration, rental, lease, and other used units may be eligible for a portion of a new unit warranty. The availability of the remaining portion of a new unit warranty does not mean that a unit is new or unused. The Warranty Period ends when either the month or machine hour limit is reached, whichever limit occurs first.

Table with 4 columns: CASE HEAVY PRODUCT, BASE WARRANTY, EXTENDED WARRANTY, Notes\*. Rows include: COMPACTION EQUIPMENT - SINGLE OR DOUBLE DRUM, WHEEL LOADERS (Case ProCare Coverage), MOTOR GRADERS (Case ProCare Coverage), EXCAVATORS (Case ProCare Coverage), CRAWLER DOZERS (Case ProCare Coverage).

- 1) Engine coverage is provided directly by the engine manufacturer.
2) Torque converter, transmission, drive shafts, & drive axles are covered for 24 months / 2000 hours.
3) Warranty does not cover any configuration excavator equipped with feller buncher/accumulator attachments
4) Units equipped with factory standard telematics are authorized for Case ProCare extended coverage for an additional 24 months / 3000 total machine hours, whichever comes first
5) Engine warranty coverage is provided through CNH Industrial.
6) Second year machine warranty coverage after base warranty expires

Operator's Manual / Warranty Receipt Verification

- YES / NO The selling dealer has reviewed the correct operator's manual with me and will provide upon delivery of the product.
YES / NO The selling dealer explained safety precautions to me.
YES / NO The selling dealer explained the warranty terms and coverage to me.
YES / NO The selling dealer explained Purchased Protection Plan options for additional coverage on select components.
YES / NO I wish to be part of future NHAG communications, offers or events.

Form with fields: Model, Serial Number, Retail DATE / HOURS, Operator Manual Number, Purchaser Name (please print), Dealer Name, Address, City / State, Zip code, Phone Number.

The answers checked above are correct. I acknowledge that I have read and I accept this warranty policy statement.

Purchaser Signature \_\_\_\_\_ Date \_\_\_\_\_

Dealer Signature \_\_\_\_\_ Date \_\_\_\_\_

USA mail original to CNH Industrial Capital America LLC, Attn: WLL Agreement, PO Box 3700, Lancaster, PA 17604-3700 USA
Overnight courier mail original to CNH Industrial Capital America LLC, Attn: WLL Agreement, 500 Diller Ave., New Holland, PA 17557
Canada mail original to CNH Industrial Capital America LLC, Attn: WLL Agreement, 4475 North Service Rd, Suite 301, Burlington, ON L7L4X7 Canada

Case is a registered trademark in the United States and many other countries, owned by or licensed to CNH Industrial N.V., its subsidiaries or affiliates

Original - CNH

Copy 2 - Purchaser

Copy 3 - Dealer

### What's Covered

If a defect in material or workmanship is found in a unit and reported during the Warranty Period, Case will pay parts and labor costs to repair the defect if the services are performed by an authorized Case dealer at the dealer's location. If parts are needed during the repair, Case will, at its option, use genuine Case new or remanufactured parts. Case replacement parts that are used in a warranty repair are warranted until the end of the machine warranty or to the end of the Case Replacement Parts Warranty, whichever is longer.

CASE PROVIDES NO WARRANTY, EXPRESS OR IMPLIED, FOR A COMPONENT OR OTHER ITEM THAT IS SEPARATELY WARRANTED TO THE PURCHASER BY ITS MANUFACTURER, SUCH AS TIRES, BATTERIES AND FUEL INJECTION COMPONENTS. CHECK WITH YOUR DEALER FOR DETAILS

### No Modification or Extension of Warranty Period

The Case Warranty is limited to the written terms in this document. Case does not authorize any person, dealer or agent to change or extend the terms of this warranty in any manner. Any assistance to the purchaser in the repair or operation of any Case product outside the terms or limitations or exclusions of this warranty will not constitute a waiver of the terms, limitations or exclusions of this warranty, nor will such assistance extend or re-establish the warranty.

### EXCLUSIVE REMEDY

**THE REMEDY OF REPAIRING A DEFECT IN MATERIALS OR WORKMANSHIP AT A CASE DEALERSHIP UNDER THE TERMS OF THIS WARRANTY IS THE PURCHASER'S EXCLUSIVE REMEDY AND IS IN LIEU OF ANY OTHER REMEDY OTHERWISE AVAILABLE.**

### This Warranty is Void If

The unit's hour meter is changed or altered, unless a Case dealer, at the direction of Case, changed the meter. If the unit is used in an application for which it is not designed or the unit has been scrapped, salvaged, stolen, junked or totaled.

**Limitation and Exclusions** The Case Warranty gives you specific legal rights and you may also have other rights, which vary, from region to region.

**THIS DOCUMENT CONTAINS THE ENTIRE CASE WARRANTY. CASE MAKES NO OTHER REPRESENTATIONS OR WARRANTIES, EXPRESSED OR IMPLIED, AND SPECIFICALLY EXCLUDES THE IMPLIED WARRANTIES OF MERCHANTABILITY AND FITNESS FOR PARTICULAR PURPOSE.\* CASE WILL NOT BE LIABLE FOR INCIDENTAL OR CONSEQUENTIAL DAMAGES RESULTING FROM A BREACH OF THE WRITTEN WARRANTY OR ANY IMPLIED WARRANTY IMPOSED BY LAW.\***

### Owner's Responsibility

The Case warranty remains in effect during the Warranty Period if the owner performs the required maintenance at the recommended intervals outlined in the product operator's manual and the unit is operated within its rated capacity. Genuine Case service parts or Case approved service parts that meet Case specifications must be used for maintenance and repair.

### What's Not Covered

- Cost associated with performing pre-delivery or scheduled inspection service.
- Repairs arising from storage deterioration, failure to maintain the equipment, negligence, alteration, improper use of the equipment, collision or other accident, vandalism, or other casualty, or operation beyond rated capacity or specification.
- Repairs arising from abuse or neglect, including but not limited to: operation without adequate coolant or lubricants, adjustments to the fuel system outside equipment specifications, over-speeding, improper storage, starting, warm-up, or shutdown practices, incorrect fuel or contaminated fuel, oil or other fluids.
- Normal maintenance services, such as engine tune-ups, engine fuel system cleaning, checks, adjustments, shimming, etc.
- Replacement of non-defective wear items expected to be replaced during the warranty period, including but not limited to: light bulbs, spark plugs, ignition points, brake or clutch linings, slip clutches, belts, chains, knives, bucket cutting edges and teeth, crawler track pads and track components, crop processing and cutting components, external drive sprockets and chains, soil engaging tools and accessories.
- Items replaced due to customer demand.
- Labor charges performed by anyone except a dealer authorized by contract to repair the equipment, unless they qualify under special provisions (i.e.; outside labor).
- Any and all travel costs for items such as towing, service calls, or transporting a unit to and from the place where the warranty service is performed, unless specifically covered by a product improvement program or units classified as heavy and/or compaction products
- Claims involving loss or damage during shipment or handling, including units subsequently sold as a "salvage" unit.
- "Salvage" or other units sold on an "as is" basis, unless otherwise specified in writing at the time of sale.
- Normal maintenance costs, including but not limited to: lubricants, coolants, fluids, fuel, filters, and associated labor. Lubricants, filters, and coolants may qualify for warranty reimbursement if they require replacement as a DIRECT RESULT of a defect in material or workmanship.
- Claims involving the inspection or reconditioning of units after storage or prior use.
- Components or items that are separately warranted directly by the manufacturer including but are not limited to: tires, tracks, engines, transmissions, batteries, fuel injection pumps, fuel injectors, etc.
- Shop comebacks: any duplicate, repeat, or comeback repair resulting from improper diagnosis, testing, or service work. This also includes repairs arising from service performed by agents not approved by Case.
- Repairs arising from any unauthorized modification to the product or the use on non-CNH Industrial parts, implements, or attachments, including but not limited to performance changing (i.e., increasing horsepower or other modifications) and/or emissions defeating modifications.
- Removal, replacement, or installation of non-CNH Industrial optional equipment, attachments or components.
- Premiums charged for overtime labor costs or out of shop expenses.
- Economic loss including lost profits, crop loss, equipment rental, or other expense.
- Unauthorized modification or updating machines without a warrantable failure based on Service Bulletin information or production changes.
- Any and all costs of special tools
- Any and all costs of dealer shop supplies incurred with repairs, including but not limited to: solvents, cleaners, anti-seize lubricants, loctite, sealant, adhesive, oil-dry, shop towels, etc. Sealant or adhesive may qualify for warranty reimbursement in certain applications requiring a large volume of sealant/ adhesive.
- Failure of the machine, its implements or attachments caused by improper field application or loading.
- Any and all costs for coolant, fuel, or lube (oil) analysis including supplies and lab recommendations.
- Cost of initial setup or installation of any optional equipment or attachments to a unit.
- Cost associated with cleaning of machine in preparation for servicing

USA mail original to CNH Industrial Capital America LLC, Attn: WLL Agreement, PO Box 3700, Lancaster, PA 17604-3700 USA  
Overnight courier mail original to CNH Industrial Capital America LLC, Attn: WLL Agreement, 500 Diller Ave., New Holland, PA 17557  
Canada mail original to CNH Industrial Capital America LLC, Attn: WLL Agreement, 4475 North Service Rd, Suite 301, Burlington, ON L7L4X7 Canada

Case is a registered trademark in the United States and many other countries, owned by or licensed to CNH Industrial N.V., its subsidiaries or affiliates

Original – CNH

Copy 2 – Purchaser

Copy 3 – Dealer